

DETECTION & SENSING

Technical Guide



ABOUT CROUZET

100+ YEARS MANUFACTURING THE FUTURE *Together*

We design and manufacture **Mechatronic Products** to turn engineering ideas into real world applications

OUR MARKETS



OUR PRODUCTS



OUR SERVICES



WE ARE GLOBAL

2000+ collaborators,
10 Manufacturing Plants,
9 Sales Offices & 4 R&D Labs

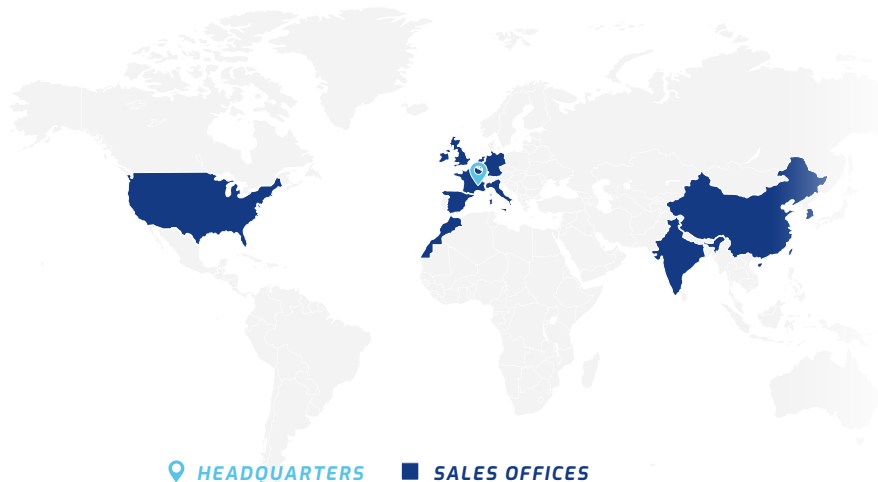

HEADQUARTERS SALES OFFICES



VALENCE, FRANCE



VALENCE NORD, FRANCE



PARIS, FRANCE



NANTES, FRANCE



ORLEANS, FRANCE



VOUVRY, SWITZERLAND



CASABLANCA 1, MOROCCO



CASABLANCA 2, MOROCCO



HUIZHOU, CHINA



BANGALORE, INDIA

CONTENTS

STANDARDS TECHNICAL BASIS

- Hermetically sealed microswitch
Types 83 151 (-55 °C to 150 °C)..... 6
- Hermetically sealed microswitches
with accessories 10
- Hermetically sealed microswitches
High pressure from 2 to 6 bar.....12
- Hermetically sealed microswitches
Types 83 151 (250 °C).....14
- Limit Switches
Based on hermetically sealed microswitches (250 °C) 15
- Limit Switches
Based on hermetically sealed microswitches (150 °C) 16
- Basic Sensitive microswitch
Type 83 141 002 (-55 °C to +150 °C)..... 18
- Waterproof limit switches
Type 83 777 based on Sensitive microswitch..... 20
- Waterproof limit switches
Type 83 778 based on Sensitive microswitch 22

CUSTOMIZED PRODUCTS

- Mechanical
Position detectors..... 24**
- Limit Switch
for thrust reverser door Tertiary Lock function 26
- Limit Switch
for thrust reverser door Stow function..... 28
- Limit Switch
for thrust reverser Maintenance Test Enable function30
- Limit Switch
for thrust reverser actuator function32
- Limit Switch for Trimmable Horizontal Stabilizer
Actuator (THSA) function.....34
- Limit Switch
for Slat function..... 36
- Limit Switch
for thrust reverser door Deploy function..... 38
- Limit Switch
for thrust reverser actuator function 40

- Limit Switch
for Helicopter Folding Tail function..... 46

- Limit Switch
for thrust reverser door Upper Secondary Lock function48

Electronic Position detectors..... 50

- Detection principle
for proximity switches and two parts sensors..... 52

- Detection principle
for proximity sensors and proximity switches..... 54

- Proximity Sensor
Rectangular passive sensor for doors function..... 56

- Proximity Sensor
Round passive sensor for landing gear function 58

- Proximity Switch
for thrust reverser actuator function 60

- Proximity Switch
All Metal for thrust reverser actuator function..... 62

- Proximity Switch
for landing gear function 64

- Proximity Switch
All metal for landing gear function..... 66

- Proximity Switch
High pressure for wind turbine function 68

- Proximity Switch
High pressure for landing gear function 70

- Proximity Switch
for cargo loading system function..... 72

- Proximity Switch
for landing gear function 76

- Proximity Switch
for thrust reverser actuator function..... 78

TERMINOLOGY

- Forces - Positions - Travel 82

A RANGE OF PRODUCTS ADAPTED TO THE DEMANDS OF THE MARKET OF DETECTION AROUND THE WORLD

In order to best serve a large diversity of applications, Crouzet offers a wide range of standard products.

From the 1-pole simple plunger switch to the 3-pole adjustable-roller plunger switch, also Crouzet offers a complete range of high-performance products which optimise volume and weight whilst functioning over a wide current range from 1 mA to 7 A.

Our extensive range is also aimed at cost reduction and rationalized stock control, and enables you to have one supplier who can ensure quality and reliability at the best price.

The aim of this document is to enable the reader to familiarise themselves with our range and to choose the product most suited to their requirements. Nevertheless, please do not hesitate to contact our representatives who are always available for advice and can supply you with additional information.

PARTNERSHIP

In response to specific customer requirements for limit switches, proximity switches and/or proximity sensors in severe environments, Crouzet offers an active partnership based on 40 years of experience.

This involves interpretation of such requirements, advice, involvement in specification development, research, prototypes, manufacture and performance testing of products.

Furthermore, Crouzet actively participates in the competitiveness of its customers' programmes. Expertise in high-performance logistics and production methods, associated with a total quality approach, minimises the global costs of product procurement and operation.

This gives increased delivery reliability, reduction in production cycles and therefore stock, product acceptance by the customer without checks etc.

Through its subsidiaries and agents, and in

particular in Europe, U.S.A. and Asia, Crouzet offers its customers efficient commercial assistance and after-sales support.

IN ALL CASES, CROUZET WILL FIND A WAY!

With Crouzet's expertise in mechanical position detectors, Crouzet offers a range of standards product, but has the ability and capacity to develop specific components, entirely adapted to the application into its environment. Today, Crouzet is a market leader in this technology for customised products.

QUALITY OF SERVICE THROUGHOUT THE PROGRAM

We remain at your side throughout the life of the program.

- › We have the in-house expertise to insure manufacturing engineering goes smoothly
- › We use up-to-date logistic tools such as IDE, to provide quality service
- › Our quality is of the highest level, ISO 9001, ISO 14001, EN / AS / JISQ / 9100 P3
- › Our production organisation is EASA part 21 approved
- › Our after-market services, EASA part 145 approved, include a specific customer support department, distributors all around the world, and an AOG service
- › NATO code: FAOX2

COMMERCIAL AIRCRAFT

AIRBUS	A318 / A319
	A320 / A321
	A330
	A340
	A350XWB
	A380
ANTONOV	AN148 / 158 / 178
ATR	42 / 72
AVIC	ARJ21
BOEING	717
	737 MAX
	747-8
	777 X
	787
BOMBARDIER	GLOBAL EXPRESS / GLOBAL 5000/6000
	G 7000 / 8000
	CRJ 700
	CHALLENGER 300/350
	CHALLENGER 601
	LEARJET 60
	LEARJET 45
CASA	C212
CESSNA	SOVEREIGN
DASSAULT	FALCON 900/900 EX/2000 / 2000 EX
	FALCON 5X / 7X / 8X
DORNIER	DO 228/328
	DO 728
DIAMOND AIRCRAFT	D-JET
ECLIPSE	ECLIPSE 500
EMBRAER	ERJ 135/145
	LEGACY 450/500
GULFSTREAM	G 150
	G 280
	G 450
	G 600
	G 650
HAWKER	HORIZON
IRKUT	MC-21
PILATUS	PC-7/PC-9
	PC-12 / PC-24
SUKHOI	SUPERJET 100

HELICOPTERS

LEONARDO	A109P
	A129
	AW139
	AW149 / 169 / 189
AIRBUS HELICOPTERS	CARACAL H225M
	COUGAR AS532
	DAUPHIN H155 / H160 / N3E
	ECUREUIL AS 350 / AS 355 / H130
	FENNEC AS550 / AS555
	NH 90
	PANTHER AS565
SUPER PUMA AS 332 / AS 225	
	TIGER
	H120 / 135 / 145 / 175
HAL	ALH/LCH
KAI	KHP

MILITARY AIRCRAFT

AIRBUS	A400M
CASA	CN235
DASSAULT	RAFALE / MIRAGE
EUROFIGHTER	EFA (TYPHOON)
HAL	LCA
	IJT 36
KAI	T50 (Golden Eagle)
PANAVIA	TORNADO
RAYTHEON	JPATS

HERMETICALLY SEALED MICROSWITCH

TYPES 83 151 (-55 °C TO 150 °C)

BASIC CELL

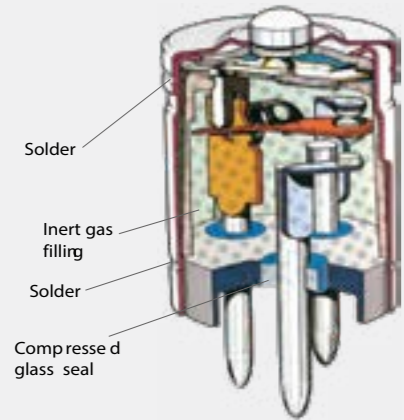

This is the basic component for our whole range of standard 1-pole and 2-poles hermetically-sealed limit switches plus the 3-poles version (special Limit Switches).

The Crouzet hermetic microswitch combines a snap-action switching system with high resistance to shock and vibration in an hermetically sealed miniature case which encloses an atmosphere of inert gas around its contacts, ideal for switching very low level circuits and higher currents also.

The meticulous care taken in the manufacture of this hermetically sealed cell in terms of assembly processes, cleanliness of components as well as inspection procedures, result in a product which is ideal for operation in severe environments where a high level of reliability is essential.

The Crouzet hermetically sealed cell is particularly well suited to sectors such as Aerospace, Armaments, Marine, Nuclear, etc.

ESSENTIAL CHARACTERISTICS

- › Switching power from 1 mA to 7 A.
- › Operating temperature: -55 °C to +150 °C (Type 83 151 2: -55 °C to +250 °C).
- › Vibration resistant up to 80 G.
- › Shock resistant up to 200 G.
- › High level of hermetic sealing: Leakage < 1×10^{-8} Pa.cm³/s
- › Long life: 200 000 cycles.
- › Small size: $\varnothing 11 \times 16$.
- › Numerous single pole and multipoles operating and fixing options.

DISTINCTIVE CHARACTERISTICS

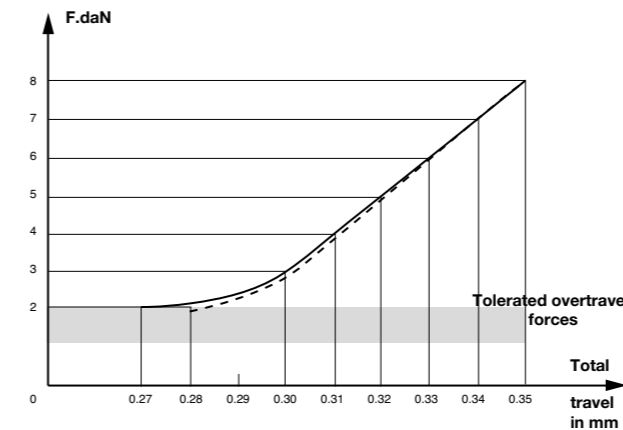

Mechanical strength

There is no sudden increase in the total travel of the detector when overtravel forces rising to as much as 80 N are applied. If, after doing this, the overtravel force is altered back to its normal level of 20 N with the same detector, only a very slight change will be apparent in the total travel (low remanence).

The detector will suffer damage if the overtravel force is raised to as much as 150 N.

Hermetic sealing

- › The microswitch is filled with inert gas (nitrogen-hydrogen mixture), the internal pressure being 1 bar.
- › The hermetic sealing (membrane-cap - cap-base) is achieved with a continuous seam welding bead. Performance in qualification helium test condition. Qualification value: 1×10^{-8} atm cm³/s.

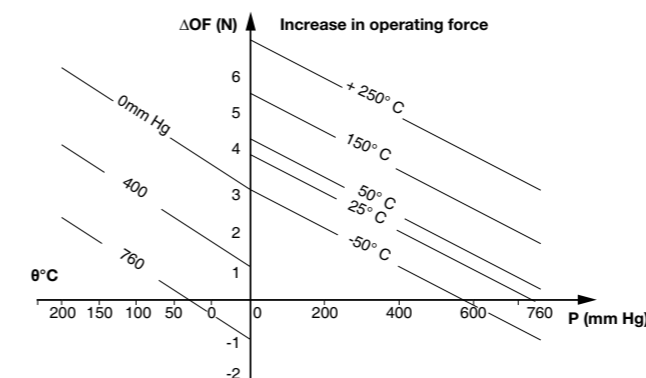

Change in operating force as a function of temperature and ambient pressure.

The force levels required to operate our hermetically sealed microswitches are affected by ambient pressure and temperature.

Here we give a graph showing how the operating force increases (ΔOF) as a function of these two parameters.

The characteristics are given for standard temperature (23 °C) and atmospheric pressure at sea level (760 mm Hg).

Our hermetically sealed microswitches can be used at pressures ranging from atmospheric to absolute vacuum and there are variants for use at higher pressures.

HERMETICALLY SEALED MICROSWITCH

TYPES 83 151 (-55 °C TO 150 °C)

Reliability of characteristics

Below are two test extracts showing the stability of the essential characteristics over time and as a function of temperature.

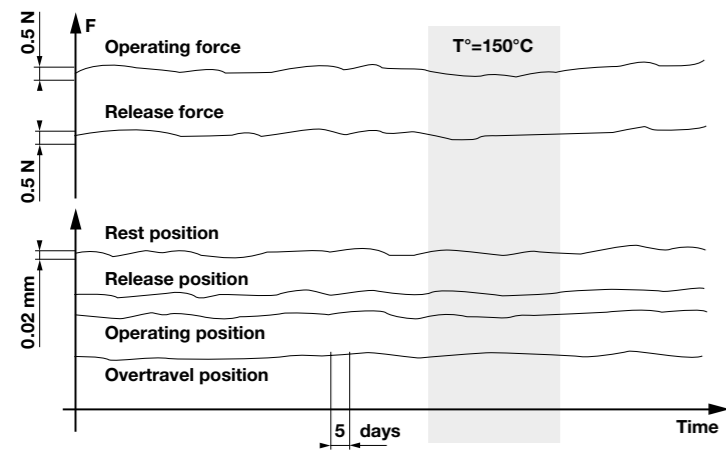

Travels and forces

Change in the characteristics concerned under a constant load of 25 Newtons applied to the operating device.

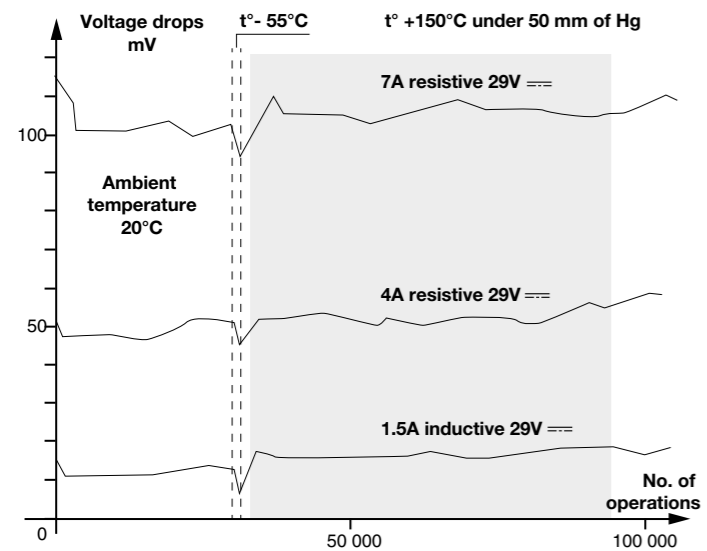

Voltage drops

Change in this characteristic in accordance with Air 8459 method - for 1.5-4 and 7 Amp load.

CONNECTIONS

Electrical connections are made through the base, by three ferronickel terminals, with copper core, sealed by compressed glass.

Soldered

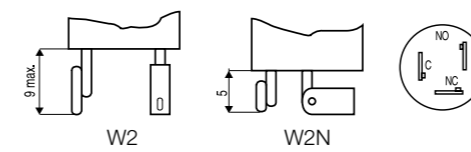

Wired

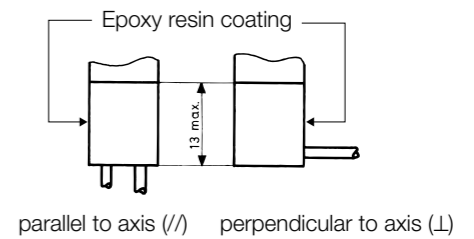

Electrical diagram (actuator at rest position)



Dimensions (mm)

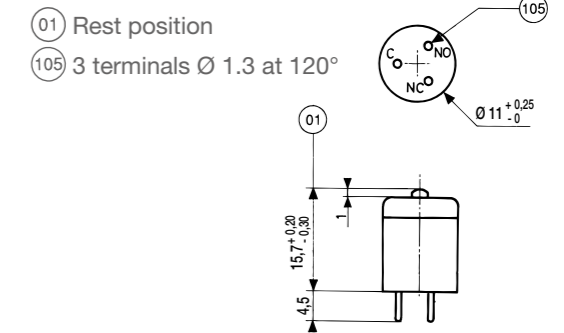

Wires: 0.38 mm² Air 4524 - length 0.50 m.
Category 140 °C 170 °C.

PERFORMANCE DATA

Product characteristics	Value	Unit	Under
Min. Current	1	mA	5 V DC
Nominal Current			
Resistive	3	A	48 V DC ⁽¹⁾
Lamp	1	A	115 V - 400 Hz
Lamp	2	A	30 V DC ⁽¹⁾
Resistive	3	A	30 V DC ⁽¹⁾
Inductive L/R = 0.005 s	1.5	A	30 V DC ⁽¹⁾
Resistive	1	A	220 V AC
Inductive - cos φ 0.8	0.4	A	220 V AC
	200 000	Cycles	
Dielectric rigidity between connections and ground	1 200	V	
Rigidity between connections	1 000	V	
Insulation resistance (at 500 V DC)	100	MΩ	
Voltage drop at 1 A ⁽²⁾	0.02	V	
Operating temperature	-55 to +150	°C	
Shock resistance ⁽³⁾	200/11	G/ms	
Vibration resistance	80/20 → 2 000	G/Hz	

(1) for a service life of 100 000 cycles - Permitted current 4 A inductive 7 A resistive for normally open or normally closed contacts.
(2) Over soldered connections - for wired connections add 0.1 V per meter.
(3) Value for microswitch without auxiliary actuator

HERMETICALLY SEALED MICROSWITCHES WITH ACCESSORIES

BASIC CELL (-55 °C TO +150 °C) TYPE 83 151 001

Criteria	Connections	with lateral flange	with 90° flange	Threaded barrel fixing
Pole(s)		1	1	1
Soldered connections	W2	83 151 012	83 151 014	83 151 013
	W2N	83 151 042	83 151 044	83 151 043
Wire 0.38 mm ² - 0.5 m long	with parallel wires	83 151 022	83 151 024	83 151 023
	with perpendicular wires	83 151 032	83 151 034	83 151 033

Characteristics	Unit			
Max. Operating force	N	10	10	10
Min. Release force	N	1.5	1.5	1.5
Permitted Overtravel force	N	20	20	20
Positive Overtravel stop				
Service life	Operations - min	200 000	200 000	200 000
Max. Pre-travel	mm	0.25	0.25	0.25
Max. Differential travel	mm	0.05	0.05	0.05
Min. Overtravel	mm	0.08	0.08	0.08
Weight (without wires)	g	5	5	13

Dimensions (mm)

Add the dimensions of the various connections to find the total dimensions

► indicates the wire direction

① Tripping point

⑪ Nut h 2.5 x 17 / flat

Panel cut-out

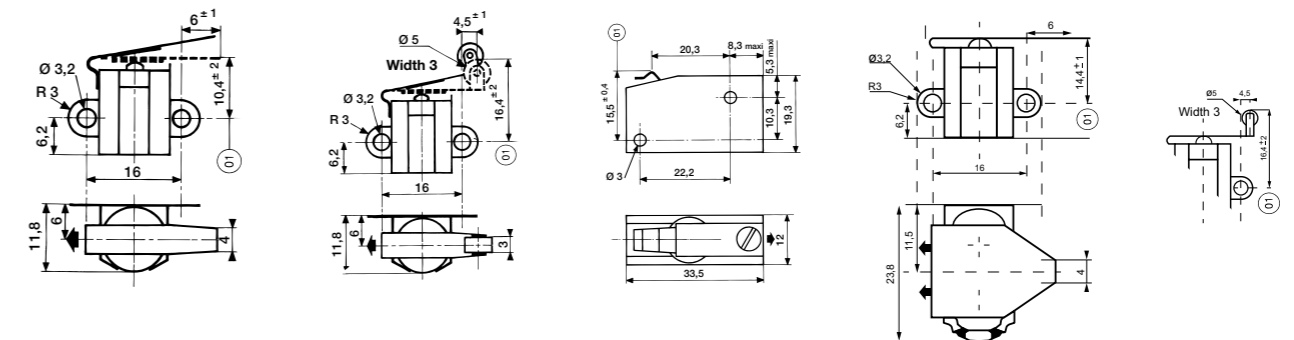
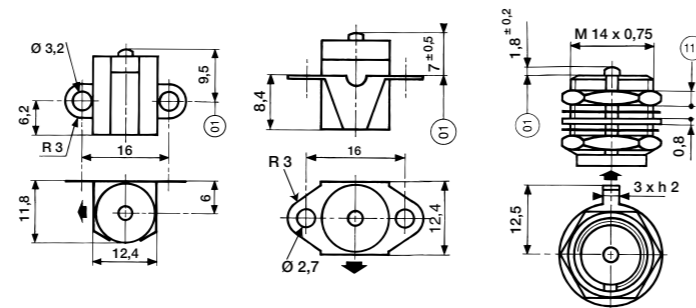
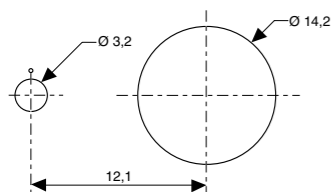

with lateral flange + lever	with lateral flange + roller lever	Housing + lever	with lateral flange + lever	with lateral flange + roller lever
1	1	1	2	2
83 560 011	83 560 012	83 560 014	83 560 311	83 560 312
83 560 041	83 560 042	83 560 049	83 560 341	83 560 342
83 560 021	83 560 022	83 560 030	83 560 321	83 560 322
83 560 031	83 560 032	83 560 039	83 560 331	83 560 332

5	5	2.5 → 8	15	15
0.5	0.5	1.5	1.5	1.5
		50		
		•		
100 000	100 000	100 000	100 000	100 000
6	6	0.3 → 0.75	6	6
0.8	0.8	0.3	1.5	1.5
0.4 → 0.8	0.4 → 0.8	0.3	0.4 → 0.8	0.4 → 0.8
6	7	21	12	13

HERMETICALLY SEALED MICROSWITCHES TYPES 83 151 (250 °C)

WITHOUT ACCESSORIES (BASIC CELL -55°C TO +250°C) TYPE 83 151 201

This basic component is the same design as the 83 151 001 standard cell but is adapted for operation in high temperatures up to 250°C.

Characteristics	Unit	Value
Nominal current at 30 VDC		
Resistive	A	1
Inductive L/R = 5 ms	A	1
Service life at nominal current	Min. operations	20 000/100 000
Voltage drop at 1 A (1)	V	0.06
Max. Operating force (2)	N	14
Min. Release force	N	1.5
Max. permitted Overtravel force	N	20
Max. Pre-travel	mm	0.25
Max. Differential travel	mm	0.05
Min. Overtravel	mm	0.08
Weight (without wires)	g	13

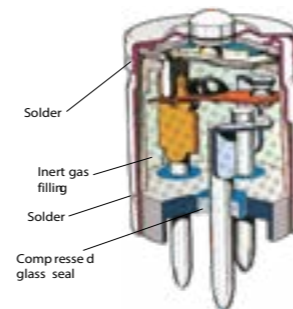

(1) On soldered connections. for wired connections add 0.18 V per meter. Category 250°, 280°.

(2) Characteristics at: $\theta = 250^{\circ}\text{C}$ atmospheric pressure at ground level.

Connections

with wires: 500 mm of length or soldered terminals

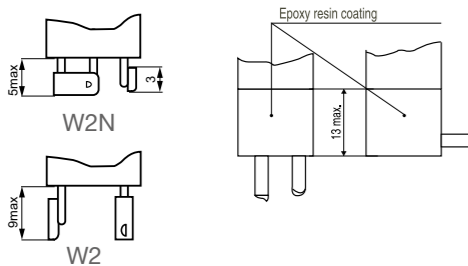

Dimensions (mm)

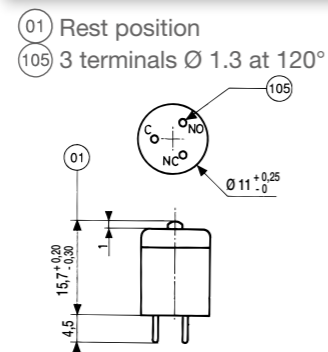

Electrical diagram

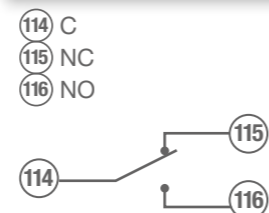

WITH ACCESSORIES (BASIC CELL -55°C TO +250°C) TYPE 83 151 201

Control accessories equipped with type 83 151 201 sensitive changeover

Criteria	1	1
Pole(s)	1	1
W2 terminals output	83 151 212	83 151 213
// wires output	83 151 222	83 151 223
┘ wires output	83 151 232	83 151 233
W2N terminals output	83 151 242	83 151 243
Weight (without wires)	6 g	13 g

Add the dimensions of the various connections for the total dimensions. The mechanical characteristics are those of the 83 151 201 changeover.
 ➤ indicates the direction of the wires.

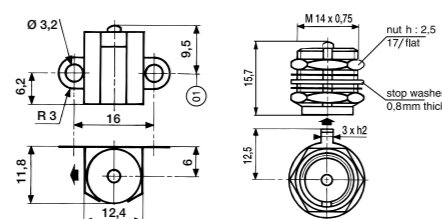

Panel cut-out

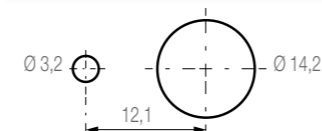

LIMIT SWITCHES - BASED ON HERMETICALLY SEALED MICROSWITCHES (250 °C)

BASIC CELL (-55°C TO +250°C) TYPE 83 151 201

Criteria	
Pole(s)	1
W2 terminals output	83 770 211
// wires output	83 770 221
┘ wires output	83 770 231
W2N terminals output	83 770 241

Dimensions (mm)

Add the dimensions of the various connections to find the total dimensions

Mechanical characteristics:

- Max. operating force: 22 N
- Min. release force: 1.5 N
- Max. permitted overtravel force: 50 N positive overtravel stop
- Pre-travel: 0.1 to 0.3 mm
- Max. differential travel: 0.05 mm
- Min. overtravel: 3 mm
- Weight (without wires): 20 g

➤ indicates the direction of the wires

Panel cut-out

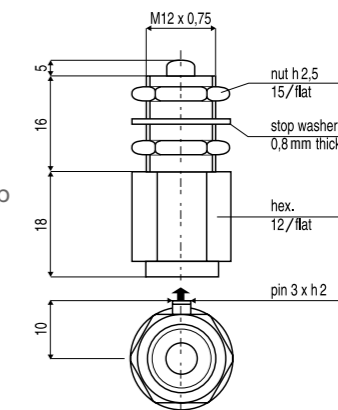
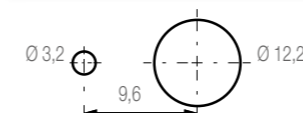

LIMIT SWITCHES - BASED ON HERMETICALLY SEALED MICROSWITCHES (150 °C)

MECHANICAL CAPACITY

We have adapted the telescopic sub-assemblies for our hermetically sealed microswitch according to pressure and operating temperature requirements. Our products can therefore be used at atmospheric pressure or in an absolute vacuum and at a temperature of -50 °C to +150 °C.

BASIC CELL (-55 °C TO +150 °C) TYPE 83 151 001

Criteria	Connections	Short travel
Pole(s)		1
Soldered connections	W2	83 770 012
	W2N	83 770 042
Wire 0.38 mm ² 0.50 m long	with parallel wires	83 770 022
	with perpendicular wires	83 770 032

Characteristics	Unit	
Max. Operating force	N	12
Min. Release force	N	1.5
Permitted Overtravel force	N	20
Positive Overtravel stop		
Max. Pre-travel	mm	0.3
Max. Differential travel	mm	0.05
Min. Overtravel	mm	1
Shock resistance	G/ms	100/11
Vibration resistance	G/Hz	50/800 → 2 000
Weight (without wires)	g	21
Service life	Operations - min	100 000

Panel cut-out	Dimensions (mm)
---------------	-----------------

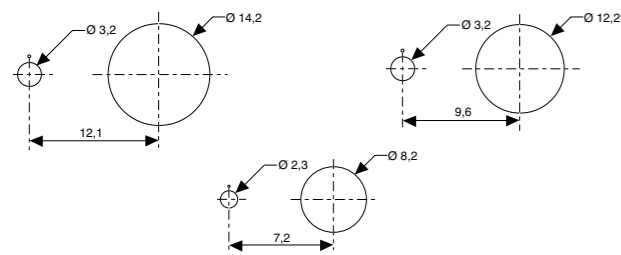

Add the dimensions of the various connections for the total dimensions
 indicates the direction of the wires

- 30 Ball bearing Ø 3
- 106 Nut h 2 - 11/flat
- 107 Stop washer - 0.8 thick
- 111 Nut h 2.5 - 17/flat
- 112 Locating pin - h.2
- 120 Nut h 2.5 - 15/flat

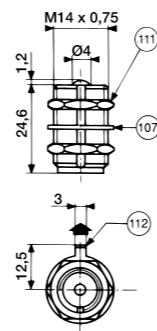

Connections

Soldered

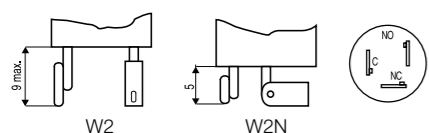

Wired

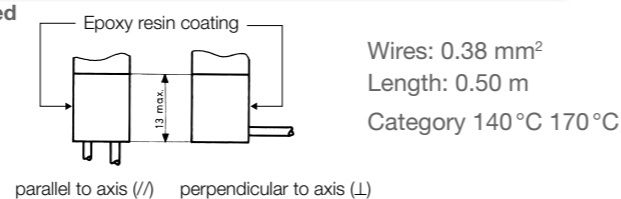

Plunger	Ball plunger	Roller Plunger	Plunger
1	1	1	2
83 770 011	83 770 014	83 770 015	83 771 011
83 770 041	83 770 044	83 770 045	83 771 041
83 770 021	83 770 024	83 770 025	83 771 021
83 770 031	83 770 034	83 770 035	83 771 031

12	12	12	30
1.5	1.5	1.5	3
50	50	50	80
•	•	•	•
0.3	0.3	0.3	0.5
0.05	0.05	0.05	0.15
3	3	3	5
100/11	100/11	100/11	100/11
50/800 → 2 000	50/800 → 2 000	50/800 → 2 000	50/800 → 2 000
15	15.5	20	47.5
100 000	100 000	100 000	100 000

Plunger	Ball plunger	Roller Plunger	Plunger
---------	--------------	----------------	---------

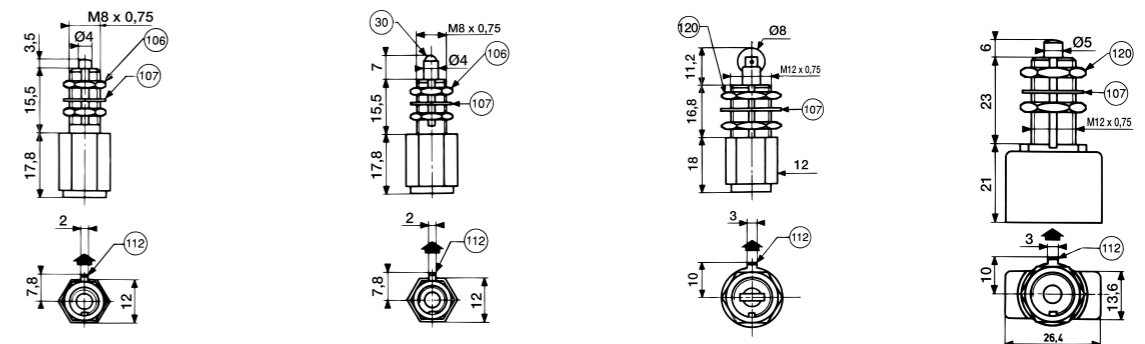

Electrical diagram (actuator at rest)



BASIC SENSITIVE MICROSWITCH

TYPE 83 141 002 (-55 °C TO +150 °C)

WITHOUT ACCESSORIES

This microswitch is notable for its excellent performance in a very compact space (13 x 10 x 5 mm). It is the basic element of our range of standard 1-pole, 2-pole, 3-pole waterproof Limit Switches, and special 4-pole Limit Switches.

The meticulous care taken in the manufacture of this microswitch in terms of assembly processes, cleanliness of components as well as inspection procedures, results in a product which is ideal for operation in severe environments where a high level of reliability is essential. It is particularly well suited to the Aerospace, Armaments, Marine sectors, etc.

This microswitch, used in our 83 777 and 83 778 series limit switches, combines a reliable snap-action switching system with high resistance to shocks and vibrations, ideal for switching both very low level and high currents.

Characteristics	Under	Unit	Value
Nominal current	10 VDC	A	0.01
Resistive	30 VDC	A	4
	220 VAC	A	1
Inductive L/R = 0.005 s	30 VDC	A	2
	220 VAC	A	0.5
Service life at nominal current*		operations - min.	100 000
Operating temperature		°C	-55 to +150
Max. Operating force		N	2
Min. Release force		N	0.4
Max. Pre-travel		mm	0.5
Max. Differential travel		mm	0.08
Min. Overtravel		mm	0.1
Weight		g	1

* Value for microswitch without auxiliary actuator

Dimensions (mm)

01 Tripping point

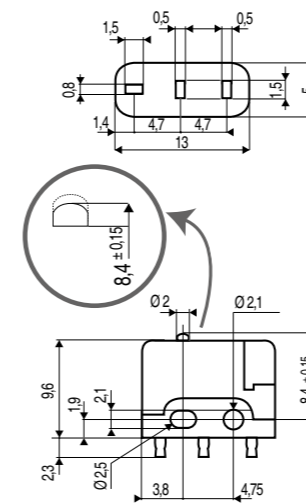

Electrical diagram

Plunger in released position

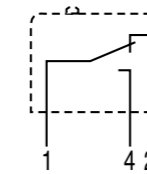

Connections

Solder tags

WATERPROOF LIMIT SWITCHES

TYPE 83 777 BASED ON SENSITIVE MICROSWITCH

This range of limit switches satisfies applications which require lightweight miniature devices without sacrificing mechanical and electrical performance.

They are particularly well suited to severe environments such as: Aerospace, Armaments, Marine, etc. The plungers for this range of limit switches are equipped with an ice-scraper seal.

BASIC SENSITIVE MICROSWITCH 83 141 002

Simple plunger

Characteristics			
Nominal current	10 VDC	A	0.01
Resistive	30 VDC	A	4
	220 VAC	A	1
Inductive L/R = 0.005 s	30 VDC	A	2
	220 VAC	A	0.5
Service life at nominal current	operations - min.	50 000	
Dielectric strength between connections and ground	V	1 500	
Dielectric strength between connections	V	1 000	
Insulation resistance (at 500 VDC)	MΩ	100	
Voltage drop at 1 A*	V	0.06	
Operating temperature	°C	-55 to +125	
Shock resistance	G/ms	50/11	
Vibration resistance	G/Hz	10/20 → 2 000	

* for flying leads, add 0.1 V / meter.

Connections

Wires: 0.38 mm² - 0.50 m long
 - Output parallel to device axis,
 - Output perpendicular to device axis

Connector: type HE 301
 - NFC 93422
 - MIL.C 26482.G series 1
 - VG 95328

Electrical diagram

Plunger in released position

- 1 pole

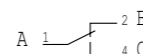

- 2 pole

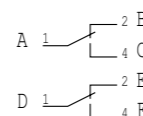

- 3 pole

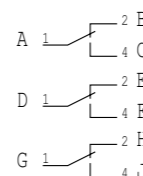

Seal

We guarantee that our products are sealed to level IP 66.

Criteria

Connection wires	parallel
	perpendicular
Connector	HE 301 1H 10 6P
	HE 301 1H 12 10P

Characteristics

Max. Operating force	N
Min. Release force	N
Max. Total travel force	N
Max. Pre-travel	mm
Max. Differential travel	mm
Min. Overtravel	mm
Weight (with wires)	g

Dimensions (mm)

- (107) Stop washer width 0.8
- (112) Locating pin
- (117) Free position
- (118) Nuts h. 2.5 - 15 on flat
- (119) Nuts h. 3 - 21 on flat
- (130) Pin h.2

Panel cut-out

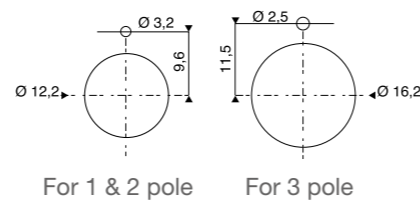

1 pole	2 pole	3 pole	1 pole	2 pole	3 pole	1 pole	2 pole	3 pole
83 777 021	83 777 321	83 777 621	83 777 011	83 777 311	83 777 611	83 777 031	83 777 331	83 777 631
•	•	•	•	•	•	•	•	•

60	60	60	60	60	60	60	60	60
10	10	18	10	10	18	10	10	18
150	150	150	150	150	150	150	150	150
1.2	1.2	1.2	1.2	1.2	1.2	1.2	1.2	1.2
0.2	0.5	0.5	0.2	0.5	0.5	0.2	0.5	0.5
3.2	3.2	5.5	3.2	3.2	5.5	3.2	3.2	5.5
30	41	80	30	41	80	34	34	73

83 777 021
83 777 321

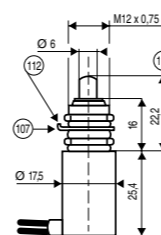

83 777 621

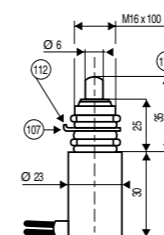

83 777 011
83 777 311

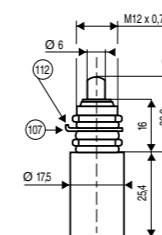

83 777 611

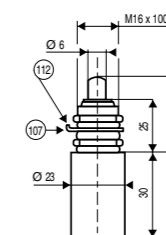

83 777 031
83 777 331

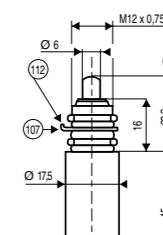

83 777 631

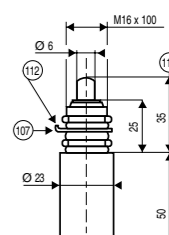

WATERPROOF LIMIT SWITCHES

TYPE 83 778 BASED ON SENSITIVE MICROSWITCH

This range of limit switches satisfies applications which require lightweight miniature devices without sacrificing mechanical and electrical performance.

They are particularly well suited to severe environments such as: Aerospace, Armaments, Marine, etc. The plungers for this range of limit switches are equipped with orientable roller.

BASIC SENSITIVE MICROSWITCH 83 141 002

Plunger with orientable roller in 45° steps

Characteristics			
Nominal current	10 VDC	A	0.01
Resistive	30 VDC	A	4
	220 VAC	A	1
Inductive L/R = 0.005 s	30 VDC	A	2
	220 VAC	A	0.5
Service life at nominal current	operations - min.	50 000	
Dielectric strength between connections and ground	V	1 500	
Dielectric strength between connections	V	1 000	
Insulation resistance (at 500 VDC)	MΩ	100	
Voltage drop at 1 A*	V	0.06	
Operating temperature	°C	-55 to +125	
Shock resistance	G/ms	50/11	
Vibration resistance	G/Hz	10/20 → 2 000	

* for flying leads, add 0.1 V/ meter.

Connections Electrical diagram

Wires: 0.38 mm² - 0.50 m long
 - Output parallel to device axis,
 - Output perpendicular to device axis

Plunger in released position

- 1 pole

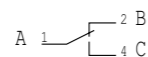

Connector: HE 301 type
 - NFC 93422
 - MIL.C 26482. G series 1
 - VG 95328

- 2 pole

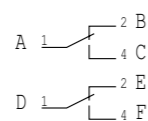

- 3 pole

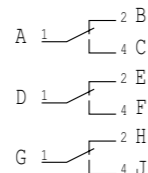

Seal

We guarantee that our products are sealed to level IP 66.

Criteria

Connection wires	parallel
	perpendicular
Connector	HE 301 1H 10 6P
	HE 301 1H 12 10P

Characteristics

Max. Operating force	N
Min. Release force	N
Max. Total travel force	N
Max. Pre-travel	mm
Max. Differential travel	mm
Min. Overtravel	mm
Weight (with wires)	g

Dimensions (mm)

- 107 Stop washer 0.8 thick
- 112 Locating pin
- 117 Free position
- 120 Nuts h. 2.5 and 6 - 15 on flat
- 121 Nuts h. 3 and 6 - 21 on flat
- 122 Roller Ø 9.6 - Width. 3
- 123 Roller Ø 12.7 - Width. 3
- 130 Pin h. 2

Panel cut-out

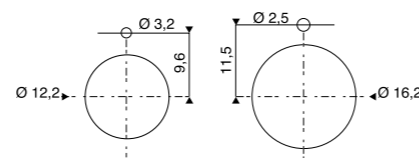

For 1 & 2 pole For 3 pole

1 pole	2 pole	3 pole	1 pole	2 pole	3 pole	1 pole	2 pole	3 pole
83 778 021	83 778 321	83 778 621	83 778 011	83 778 311	83 778 611	83 778 031	83 778 331	83 778 631
•	•	•	•	•	•	•	•	•

60	60	60	60	60	60	60	60	60
10	10	18	10	10	18	10	10	18
150	150	150	150	150	150	150	150	150
1.2	1.2	1.2	1.2	1.2	1.2	1.2	1.2	1.2
0.2	0.5	0.5	0.2	0.5	0.5	0.2	0.5	0.5
3.2	3.2	5.5	3.2	3.2	5.5	3.2	3.2	5.5
37	46	87	37	46	87	40	40	80

Dimensions (mm)

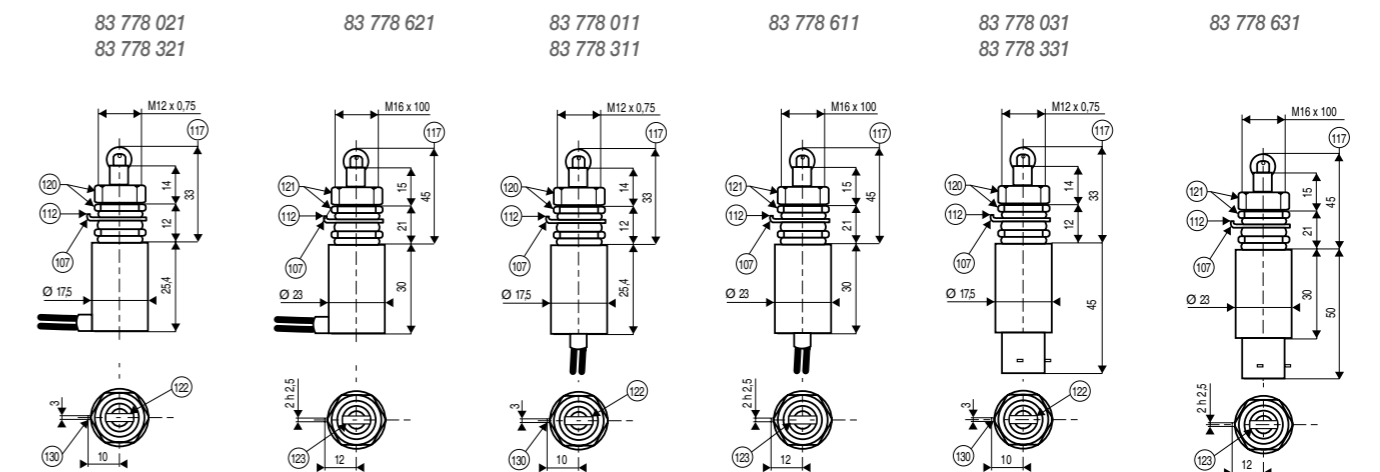

MECHANICAL POSITION DETECTORS



Limit switch

IN ALL CASES, CROUZET WILL FIND A WAY!

with Crouzet's expertise in mechanical position detectors, Crouzet offers a range of standard product, but has the ability and capacity to develop specific components, entirely adapted to the application into its environment.

Today, Crouzet is a market leader in this technology for customised products.

CROUZET PROVIDES UPON REQUEST:

- › Hermetic cells
- › Special housings
- › Cable or connector output
- › Multi-pole functions
- › Multi-actuation systems
- › High speed actuation
- › High temperature devices



Limit switches

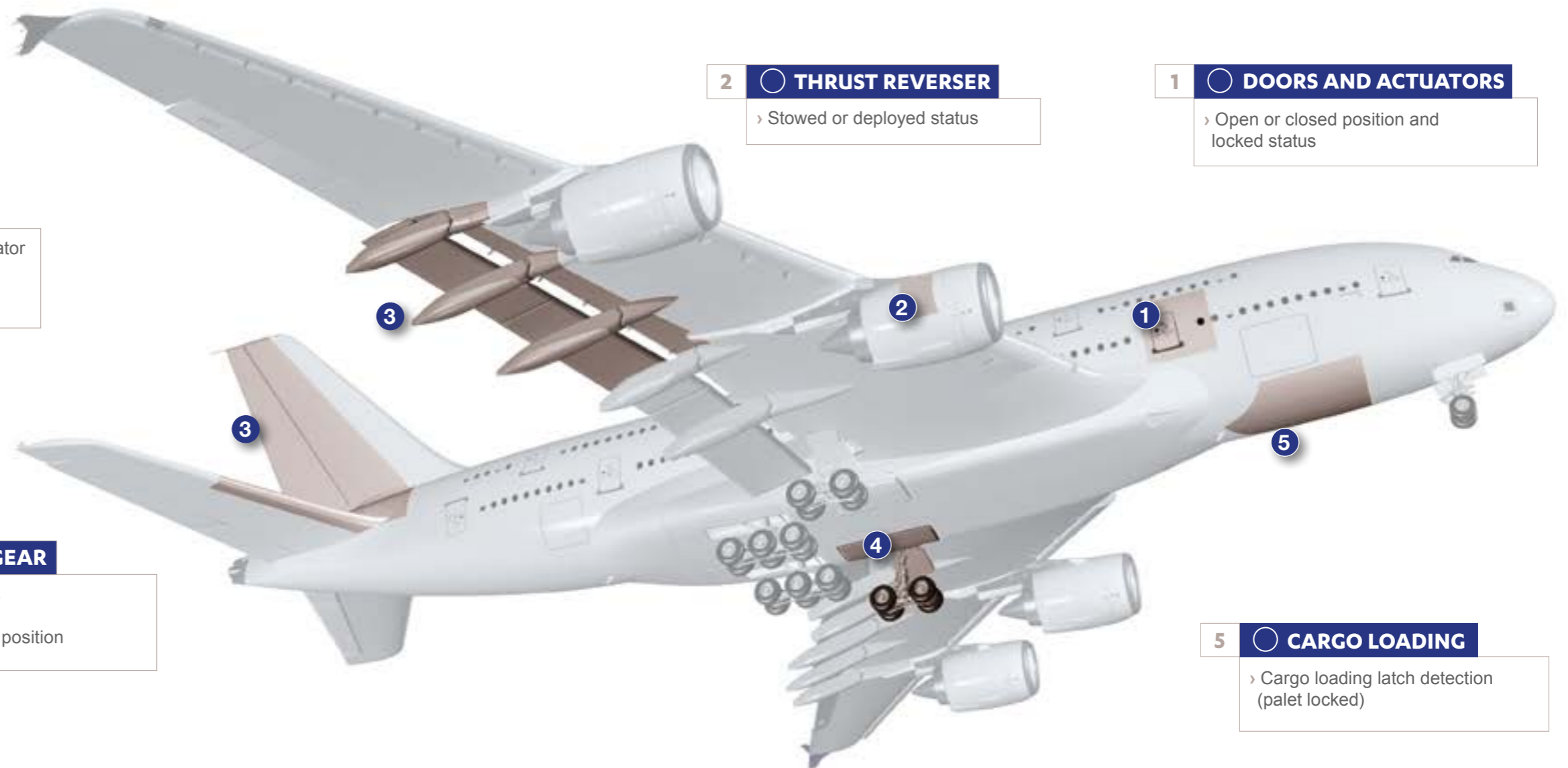

3 FLIGHT CONTROL

- › Trimable Horizontal Stabilizer Actuator
- › Spoilers
- › Flap & slat

2 THRUST REVERSER

- › Stowed or deployed status

1 DOORS AND ACTUATORS

- › Open or closed position and locked status

4 LANDING GEAR

- › Weight on wheels
- › Up position
- › Down and locked position

5 CARGO LOADING

- › Cargo loading latch detection (palet locked)

LIMIT SWITCH

FOR THRUST REVERSER DOOR TERTIARY LOCK FUNCTION

Specifications

Part numbers **DDP770375**



Summary of environmental conditions

Condition	RTCA / DO-160E	Requirement
Operating low temperature	Section 4	Category F3 (-40 °F / -40 °C)
Operating high temperature	Section 4	Category F3 (+225 °F / +108 °C)
Short-time operating temperature	Section 4	Category F3 (+225 °F / +108 °C)
Ground survival low temperature	Section 4	Category F3 (-67 °F / -55 °C)
Ground survival high temperature	Section 4	Category F3 (+250 °F / +121 °C)
Temperature variation	Section 5	Category A
Thermal shock	-	2 hours @ -67 °F (-55 °C), Operation: 5 cycles within 1 min
Altitude	Section 4	Category F3 (-2 000 to +55 000 feet)
Humidity, Waterproofness and Icing	-	CET Method I or II test
Operational shock	Section 7	Category A
Crash shock	Section 7	Category A
Vibration	Section 8	Category R, Curve W
Explosion	Section 9	Environment I, Category A
Fluid susceptibility	Section 11	Category F
Sand and Dust	Section 12	Category D
Fungus resistance	Section 13	Category F
Salt fog	Section 14	Category T
Magnetic effects	Section 15	Category Z
Power input	Section 16	Category A
Voltage spike	Section 17	Category A
Audio frequency conducted susceptibility	Section 18	Category Z
Induced signal susceptibility	Section 19	Category Z
Radio frequency susceptibility	Section 20	Category W
Emission of radio frequency energy	Section 21	Category H
Lightning-induced transient susceptibility	Section 22	Category A4 / C4
ESD susceptibility	Section 25	Category A
Flammability	Section 26	Category A

Electrical characteristics

Minimum Operational voltage	12 VDC
Maximum Operational voltage	32 VDC
Close circuit current	2 to 500 mA
Min. Open circuit resistance (Dry)	100 000 Ω
Max. Closed circuit resistance	10 Ω
Bonding resistance: (connector to switch body)	2.5 mΩ new, 10 mΩ field service
Contacts	Gold, hermetically sealed
Insulation resistance	100 MΩ min at 68 °F (20 °C) at 500 V DC for 60 sec.
Dielectrical withstanding	1 060 V rms / 50-60 Hz / 60 s (II < 1 mA)

Mechanical characteristics

Plunger impact speed	19 in/s (0,5 m/s) Max.
Impact angle	6° Max.
Actuator speed	150 in/s (4 m/s) Max.
Shock	< 100 G 11 ms
Weight	0.3 lb (130 g) Max.
Mechanical lifetime	120 000 Cycles TBC
Differential travel	0.010 in (0.254mm) Max.
Over travel	0.118 in (3 mm) Min.
Operating force	6-12 lb (27-54 N)
Full over travel force	20 lb (90 N) Max.
Release force	3.4 lbs (15 N) Min.

Principles

Electrical shematic (switch in free position)

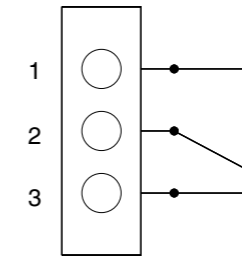

Dimensions (mm)

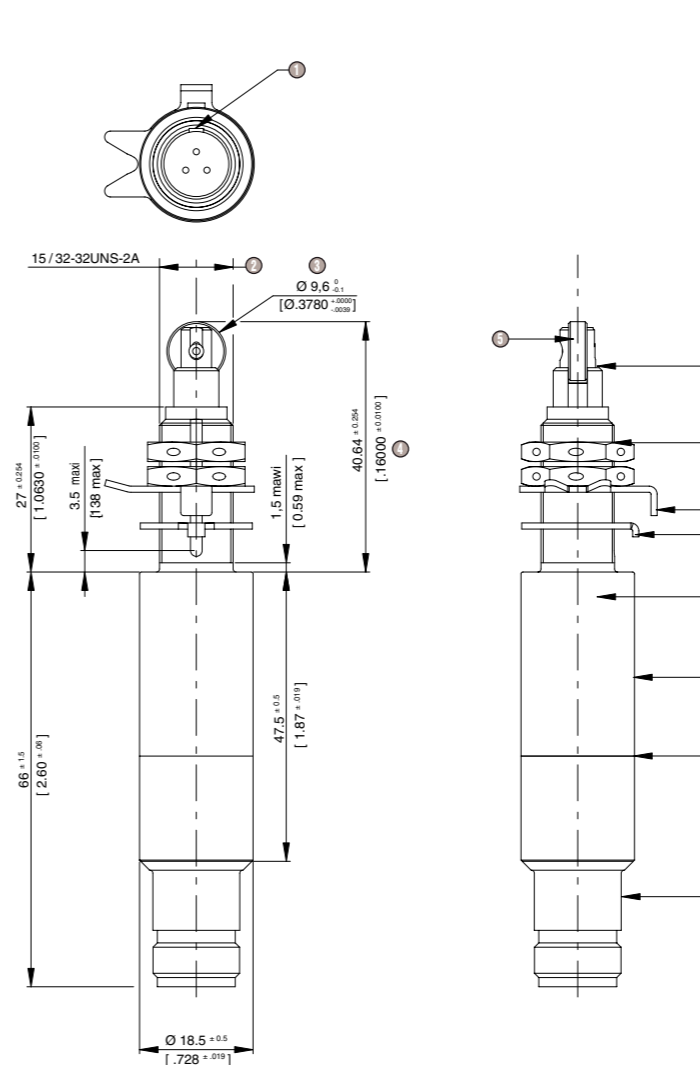

- ① Master keyway location to bushing keyway
- ② 15 / 32-32UNS-2A
- ③ Roller material: CuNi14Al2
- ④ Switching point
- ⑤ Roller orientation location to keyway slot: 90°±5°
- ⑥ Plunger stainless steel
- ⑦ (2x) steel nut MS21340-04
- ⑧ Lockwasher MS9582-14
- ⑨ Tabwasher MS25081-C4 or equivalent
- ⑩ Laser marking
- ⑪ Housing stainless steel AISI 303 (2 welding parts)
- ⑫ Watertight welding cordon
- ⑬ Connector per 8000 YE10803 PN-M108 stainless steel

LIMIT SWITCH

FOR THRUST REVERSER DOOR STOW FUNCTION

Specifications

Part numbers

DDP990202

Summary of environmental conditions

Condition	RTCA/DO-160E	Requirement
Operating low temperature	Section 4	Category F3 (-40 °F/-40 °C)
Operating high temperature	Section 4	Category F3 (+225 °F/+108 °C)
Short-time operating temperature	Section 4	Category F3 (+225 °F/+108 °C)
Ground survival low temperature	Section 4	Category F3 (-67 °F/-55 °C)
Ground survival high temperature	Section 4	Category F3 (+250 °F/+121 °C)
Altitude	Section 4	Category F3 (-2 000 to +55 000 feet)
Temperature variation	Section 5	Category A
Humidity	Section 6	Category C
Operational shock	Section 7	Category B
Crash shock	Section 7	Category B
Vibration	Section 8	Category R, Curve W
Explosion	Section 9	Environment I Category A
Waterproofness	Section 10	Category S
Fluid susceptibility	Section 11	Category F
Sand and Dust	Section 12	Category D
Fungus resistance	Section 13	Category F
Salt spray	Section 14	Category T
Magnetic effects	Section 15	Category Z
Power input	Section 16	Category A
Voltage spike	Section 17	Category A
Audio frequency conducted susceptibility	Section 18	Category Z
Induced signal susceptibility	Section 19	Category Z
Radio frequency susceptibility	Section 20	Category W
Emission of radio frequency energy	Section 21	Category H
Lightning induced transient susceptibility	Section 22	Category A4/C4
Icing	Section 24	Category A
ESD susceptibility	Section 25	Category A



Electrical characteristics	
Minimum operational voltage	12 VDC
Nominal operational voltage	28 VDC
Maximum operational voltage	32 VDC
Close circuit current	2 mA to 10 mA
Min. Open circuit resistance (dry)	50 KΩ
Max. Closed circuit resistance	30 Ω
Bonding resistance (connector housing to switch body)	2.5 mΩ new 10 mΩ field service
Contacts	Gold, hermetically sealed
Insulation resistance	100 MΩ min at 68 °F (20 °C) at 500 V DC for 60 sec.
Dielectrical withstanding	1 060 V rms/50-60 Hz/60 s (II < 1 mA)
Sealing	Watertight: MIL PRF 8805 S3

Mechanical characteristics	
Weight	0.670 lb (0.304 kg) max
Mechanical lifetime	60 000 Cycles
Release force	4.5 lb (21 N) max
Operating force	6-12 lb (27-54 N)
Full over travel force	20 lb (90 N) max

Principles

Circuit diagram (switch show in free position)

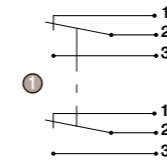

① Gold contacts

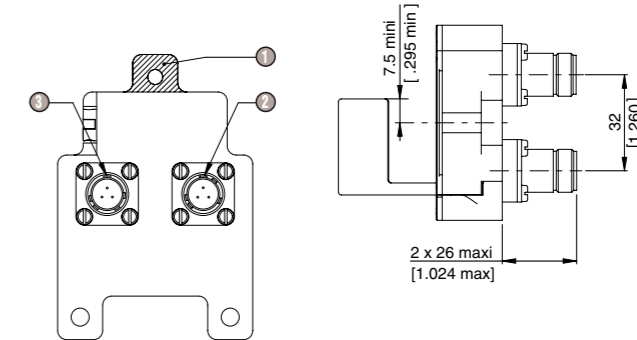

- ① Bonding surface optional
- ② Connectors EN2997-Y00803M6
Master key orientation ±10°
- ③ Connectors EN2997-Y00803MN
Master key orientation ±10°

Dimensions (mm)

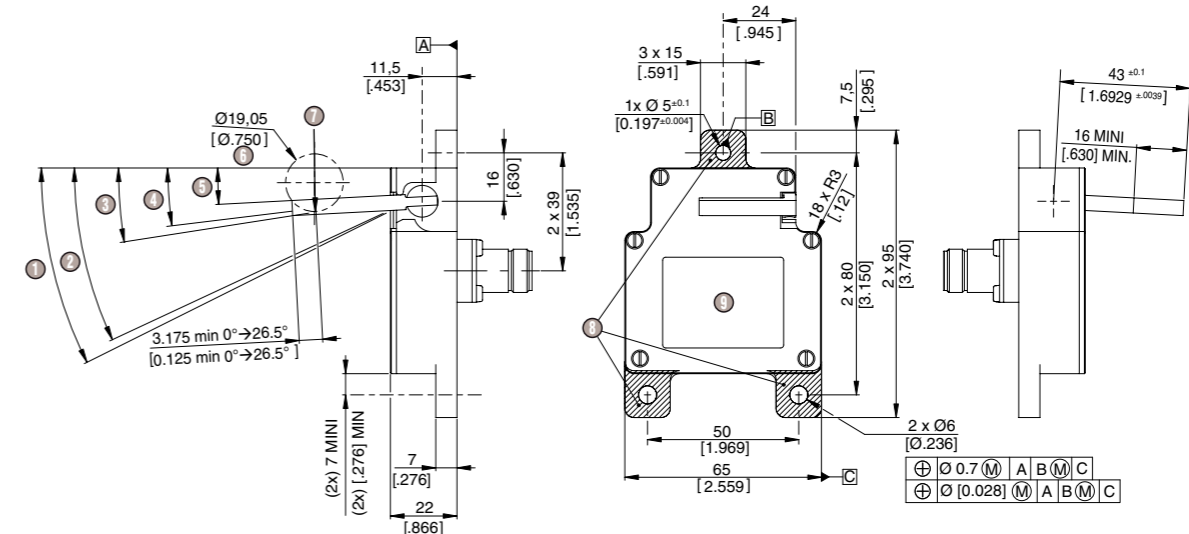

- ① 26.5° Min. Over travel
- ② 25° Max. Overstow position
- ③ 9° Max. Min. Stow position
- ④ 6.5^{+0.2}±1.5 s Switch point
- ⑤ 3.5^{-0.5}+1° Rest position
- ⑥ Roller
- ⑦ Force
- ⑧ Bonding surface (3x)
- ⑨ Electrochemically or Laser marking area

LIMIT SWITCH

FOR THRUST REVERSER MAINTENANCE TEST ENABLE FUNCTION

Specifications

Part numbers

DDP770384

Summary of environmental conditions

Condition	RTCA/DO-160E	Requirement
Operating low temperature	Section 4	Category F3 (-40°F/+40°C)
Operating high temperature	Section 4	Category F3 (+225°F/+108°C)
Short-time operating high temperature	Section 4	Category F3 (+225°F/+108°C)
Ground survival low temperature	Section 4	Category F3 (-67°F/-55°C)
Ground survival high temperature	Section 4	Category F3 (+250°F/+121°C)
Altitude	Section 4	Category F3 (-2 000 to +55 000 feet)
Temperature variation	Section 5	Category A
Operational shock	Section 7	Category B
Crash shock	Section 7	Category B
Vibration	Section 8	Category R, Curve W
Explosion proofness	Section 9	Environment I Category A
Fluid susceptibility	Section 11	Category F
Sand and Fog	Section 12	Category D
Fungus resistance	Section 13	Category F
Salt spray	Section 14	Category T
Magnetic effects	Section 15	Category Z
Power input	Section 16	Category A
Voltage spike	Section 17	Category A
Audio frequency conducted susceptibility	Section 18	Category Z
Induced signal susceptibility	Section 19	Category Z
Radio frequency susceptibility	Section 20	Category W
Emission of radio frequency energy	Section 21	Category H
Lightning-induced transient susceptibility	Section 22	Category A4/C4
ESD susceptibility	Section 25	Category A
Flammability	Section 26	Category A
Thermal shock	/	Stab. 2h at -67°F, 5 cycles within 1 min
Combined environment test	/	Method II



Electrical characteristics	
Min. Operational voltage	12 VDC
Max. Operational voltage	32 VDC
Close circuit current	4 mA to 10 mA
Min. Open circuit resistance (Dry)	50 kΩ
Max. Closed circuit resistance	30 Ω
Bonding resistance (connector housing to switch body)	2.5 mΩ new, 10 mΩ field service
Contacts	Gold, hermetically sealed
Insulation resistance	100 MΩ min at 68°F (20°C) at 500 V DC for 60 sec.
Dielectrical withstanding	1 060 V rms/60 Hz/60 s (II < 1 mA)

Mechanical characteristics	
Impact speed	19 in/s (0.5 m/s) max Operating: 4 in/s (0.1 m/s)
Weight	0.221 lb (0.100 kg) max
Mechanical lifetime	20 000 Cycles
Pre-travel	0.05 in (1.27 mm) max
Differential travel	0.010 in (0.25 mm) max
Over travel	0.06 in (1.52 mm) min
Operating force	3.15 lb (14 N) max
Release force	0.68 lb (3 N) min
Full over travel force	6.07 lb (27 N) max

Principles

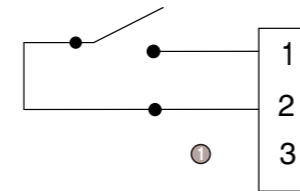

① Gold contacts

Dimensions (mm)

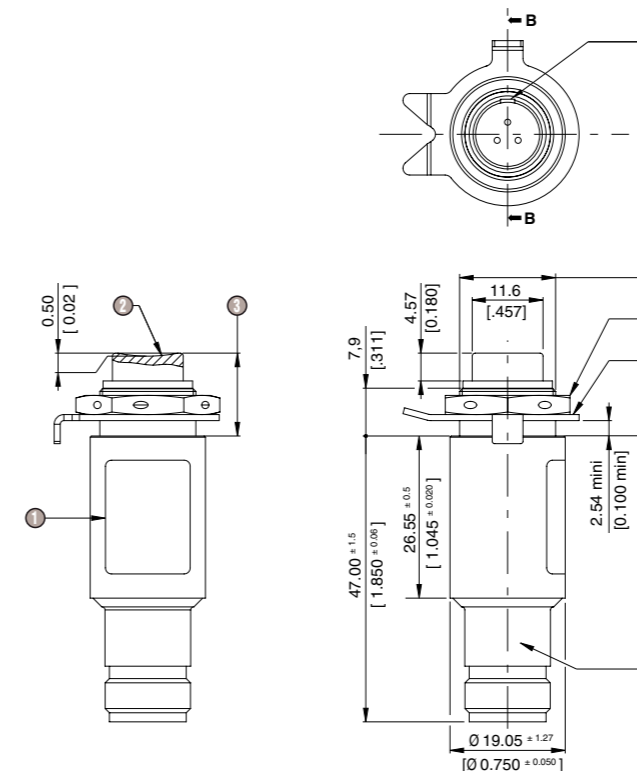

- ① Electrochemically or Laser marking
- ② SR 25.4 [1.00]
- ③ Rest position 13.70 [0.54]
- ④ Master keyway on connector ±10°
- ⑤ 0.625-24 UNEF-2A
- ⑥ Nut or equivalent: MS21340-05
- ⑦ Lockwasher or equivalent: MS9582-16
- ⑧ Bonding surface
- ⑨ Connector EN2997Y10803MN or equivalent

LIMIT SWITCH

FOR THRUST REVERSER ACTUATOR FUNCTION

Specifications

Part numbers

DDP771009

Summary of environmental conditions

Condition	RTCA / DO-160E	Requirement
Operating low temperature	Section 4	Category F3 (-40°F / -40°C)
Operating high temperature	Section 4	Category F3 (+225°F / +108°C)
Short-time operating temperature	Section 4	Category F3 (+225°F / +108°C)
Ground survival low temperature	Section 4	Category F3 (-67°F / -55°C)
Ground survival high temperature	Section 4	Category F3 (+250°F / +121°C)
Altitude	Section 4	Category F3 (-2 000 to +55 000 feet)
Temperature variation	Section 5	Category A
Humidity	Section 6	Category C
Operational shock	Section 7	Category A
Crash shock	Section 7	Category A
Vibration	Section 8	Category R, Curve W
Explosion	Section 9	As required by design
Waterproofness	Section 10	Category S
Fluid susceptibility	Section 11	Category F
Sand and Dust	Section 12	Category D
Fungus resistance	Section 13	Category F
Salt spray	Section 14	Category T
Magnetic effects	Section 15	Category Z
Power input	Section 16	Category A
Voltage spike	Section 17	Category A
Audio frequency conducted susceptibility	Section 18	Category Z
Induced signal susceptibility	Section 19	Category Z
Radio frequency susceptibility	Section 20	Category W
Emission of radio frequency energy	Section 21	Category H
Lightning-induced transient susceptibility	Section 22	Category A4 / C4
Icing	Section 24	Category A
ESD susceptibility	Section 25	Category A
Flammability	Section 26	Category A



Electrical characteristics

Min. Operational voltage	14 VDC
Nominal operating voltage	28 VDC
Max. Operational voltage	32 VDC
Closed circuit current	2 mA to 500 mA
Min. Open circuit resistance (Dry)	500 000 Ω
Max. Closed circuit resistance	10 Ω
Contacts	Gold, hermetically sealed
Insulation resistance	100 MΩ Min. at 68 °F (20 °C) at 500 V DC for 60 sec.
Dielectrical withstanding	1 060 V rms/60 Hz/60 s (II < 1 mA)

Mechanical characteristics

Impact speed	1 in/s (25.4 mm/s) Max.
Shock	< 100 G 11 ms
Weight	0.260 Lb (0.118 Kg) Max.
Mechanical lifetime	20 000 Cycles
Differential travel	0.020 in (0.5 mm) Max.
Over travel	0.157 in (4 mm) Min.
Operating force	6-14 Lb (27-62.5 N)
Full over travel force	30 Lb (133 N) Max.
Release force	3.4 Lb (15 N) Min.

Principles

Circuit diagram (switch show in free position)

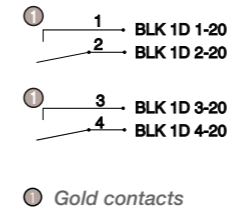

Dimensions (mm)

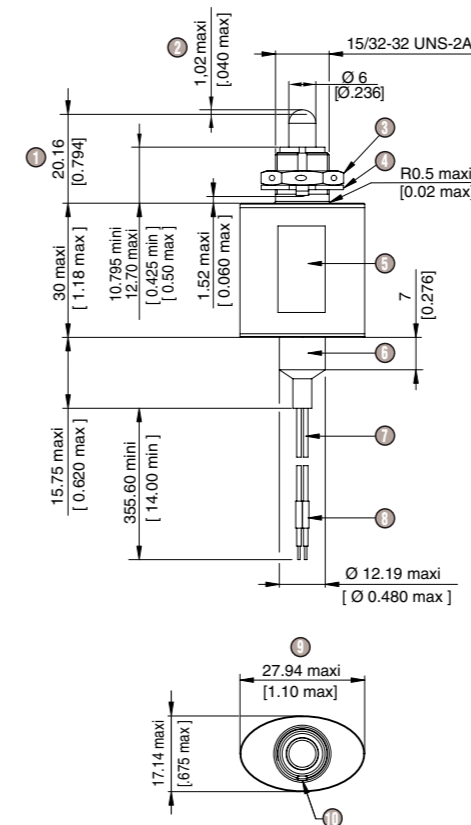

- ① Switch point
- ② Pre-travel
- ③ Hex nuts MS21340-04 or equivalent
- ④ Keying washer: MS25081-C4 or equivalent
- ⑤ Laser or electrochemically etch
- ⑥ Heat shrinkable boot per MIS-34867
- ⑦ Wire 24 AWG per NEMA HP3
- ⑧ Sleeves marks
- ⑨ View without nut and washer
- ⑩ Keyway: [.078 ±.003] wide, [.040 ±.002] deep

LIMIT SWITCH

FOR TRIMMABLE HORIZONTAL STABILIZER ACTUATOR (THSA) FUNCTION



Specifications

Part numbers **DDP770345**

Environment characteristics	
Operating temperature	-55°C to +90°C
Number of cycles head on	200
Max. Pre-travel	0.5 mm
Max. Movement differential	0.06 mm
Min. Overtravel	3 mm
Operating force on all the range of temperature	10 to 30 N
Min. Release force	6 N
Max. Total travel force	72 N
Speed of attack	0.7 m/s Max.
Max. Coupling torque	5 N.m
Traction on wires	15 N Max.
Weight	90 g Max.
Storage limit time	10 Years See: NF L 17-103

Principles

Electrical scheme released in free posi-

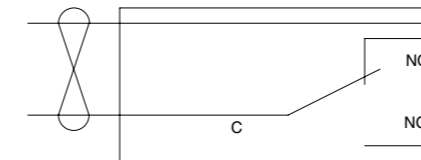

Dimensions (mm)

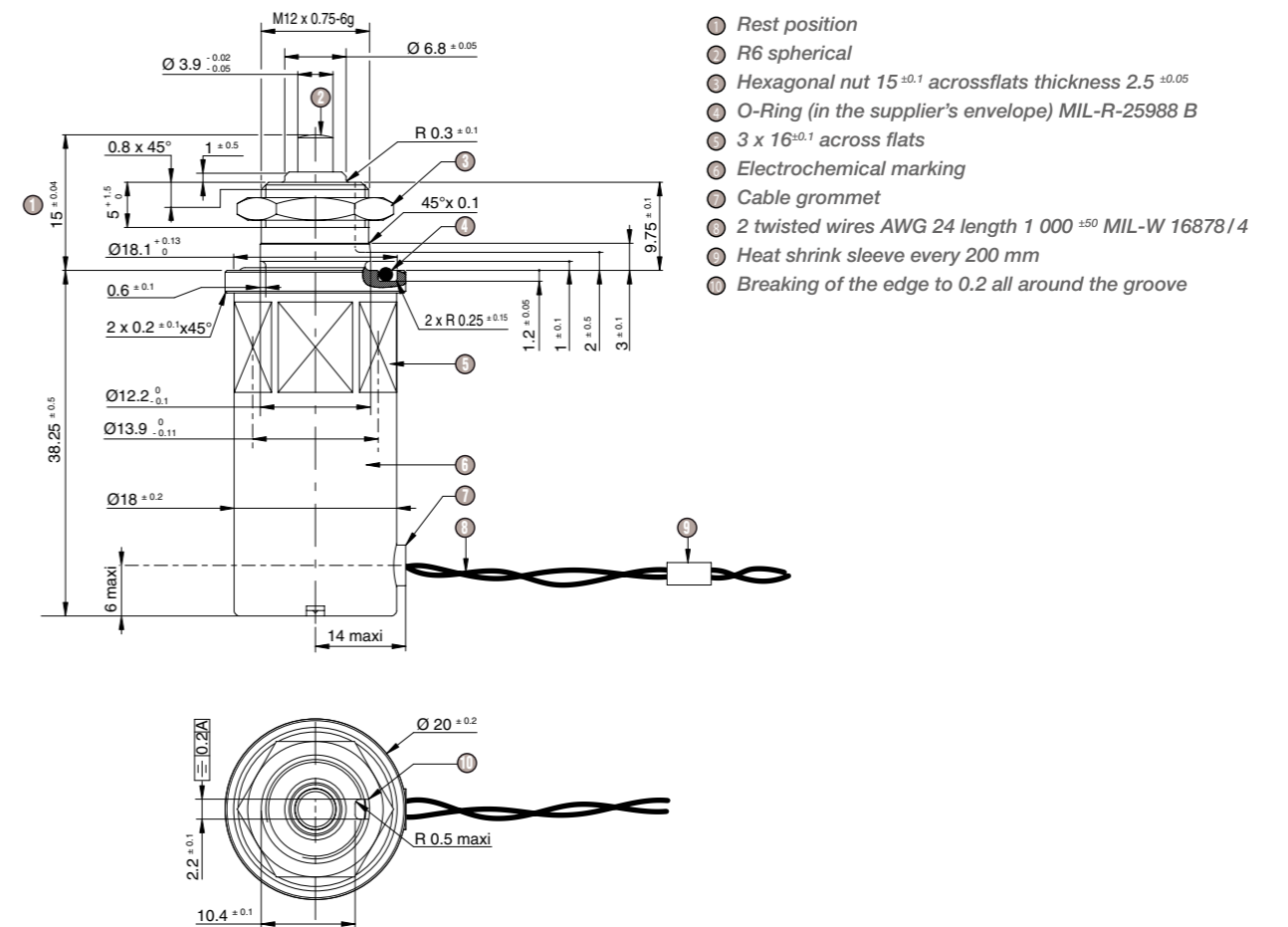

LIMIT SWITCH FOR SLAT FUNCTION



Specifications

Part numbers

DDP770348

Mechanical characteristics

The characteristics are given for standard temperature (23°C) and atmospheric pressure at the sea level (760 mm Hg)

Operating temperature	-55°C to +70°C
Exceptional operation during 5 minutes	+85°C
Storage temperature	-55°C to +85°C
Number of cycles head on	100 000
Max. Pre-travel	1 mm
Max. Movement differential	0.5 mm
Min. Overtravel	3 mm
Operating force	25 to 55 N
Max. total travel force	90 N
Weight	79 g Max.

Principles

Circuit diagram rest position

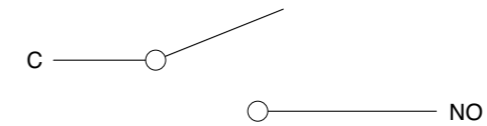

Dimensions (mm)

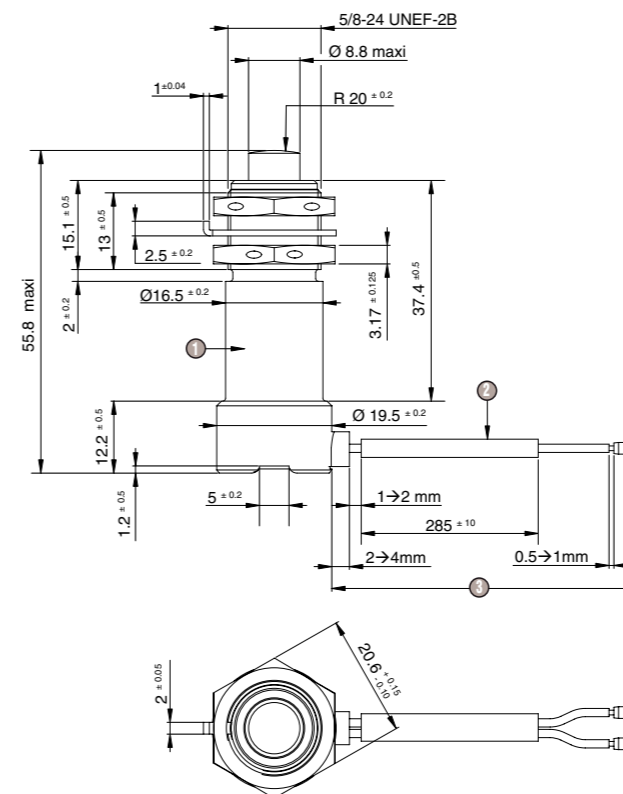

- ① Electro etching marking
- ② Sleeve DR25
- ③ 2 wires KZ05-07 AWG 20 length 336±5

LIMIT SWITCH

FOR THRUST REVERSER DOOR DEPLOY FUNCTION



Specifications

Part numbers **DDP771067**

Environment characteristics

Conditions	RTCA/DO-160D	Requirements
Equipment intended for installation in powerpoint	Section 4.3	Category D3
Operating low temperature	Section 4	Category D3 -40 °C
Operating high temperature	Section 4	Category D3 +135 °C
Short time operating high temp.	Section 4	Category D3 +135 °C
Ground survival low temperature	Section 4	Category D3 -62 °C
Ground survival high temperature	Section 4	Category D3 +85 °C
Altitude	Section 4	Category D3 45000 ft
Temperature variation	Section 5	Category A
Humidity	Section 6	Category B
Operating shock	Section 7	Category B
Crash shock	Section 7	Category B
Vibrations	Section 8	Category H2
Explosion	Section 9	Category E2
Waterproofness	Section 10	Category R
Fluid susceptibility	Section 11	Category F Spray test
Sand and Dust	Section 12	Category D
Fungus resistance	Section 13	Category F
Salt spray	Section 14	Category S
Lightning induced transient susceptibility	Section 22	Category A4XX
Icing	Section 24	Category B

Electrical characteristics

Normal Operating voltage	28 VDC
Max. Operating voltage	32 VDC
Normal Operating current	10 mA < I < 50 mA
Max. Operating current	100 mA
Contact resistance	125 mΩ Max.
Dielectric withstanding at atmospheric pressure	1 000 VRMS - 1 mA
Electrical bonding	2.5 mΩ between the bush and the beginning of the shield under the sleeve
Insulation resistance	100 MΩ at 500 VDC
Electrical Lifetime	100 000 Cycles
Contact bounce: (Checked during shocks and vibrations tests)	< 5 ms

Mechanical characteristics

The characteristics are given for standard temperature (23 °C) and atmospheric pressure at the sea level (760 mm Hg).
Braided shield grounded to body of switch for 360°.

Operating force	to be less than 12 lbs
Pretravel	0.04 inch Max.
Differential travel	0.02 inch Max.
Overtravel	0.125 inch Min.
Mechanical lifetime	100 000 Cycles
Weight	300 g Max.
Operating attack speeds	0.5 m/s Max.
Outstaded Max. attack speeds permitted	0.7 m/s
Product sealing	Watertight
Cell sealing	Hermetic

Principles

Circuit diagram (switch show in free position)

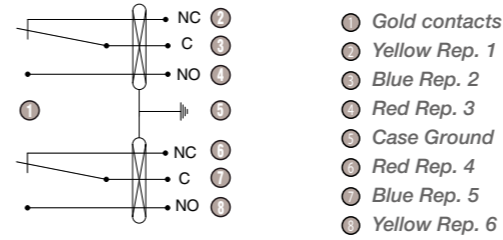

Dimensions (mm)

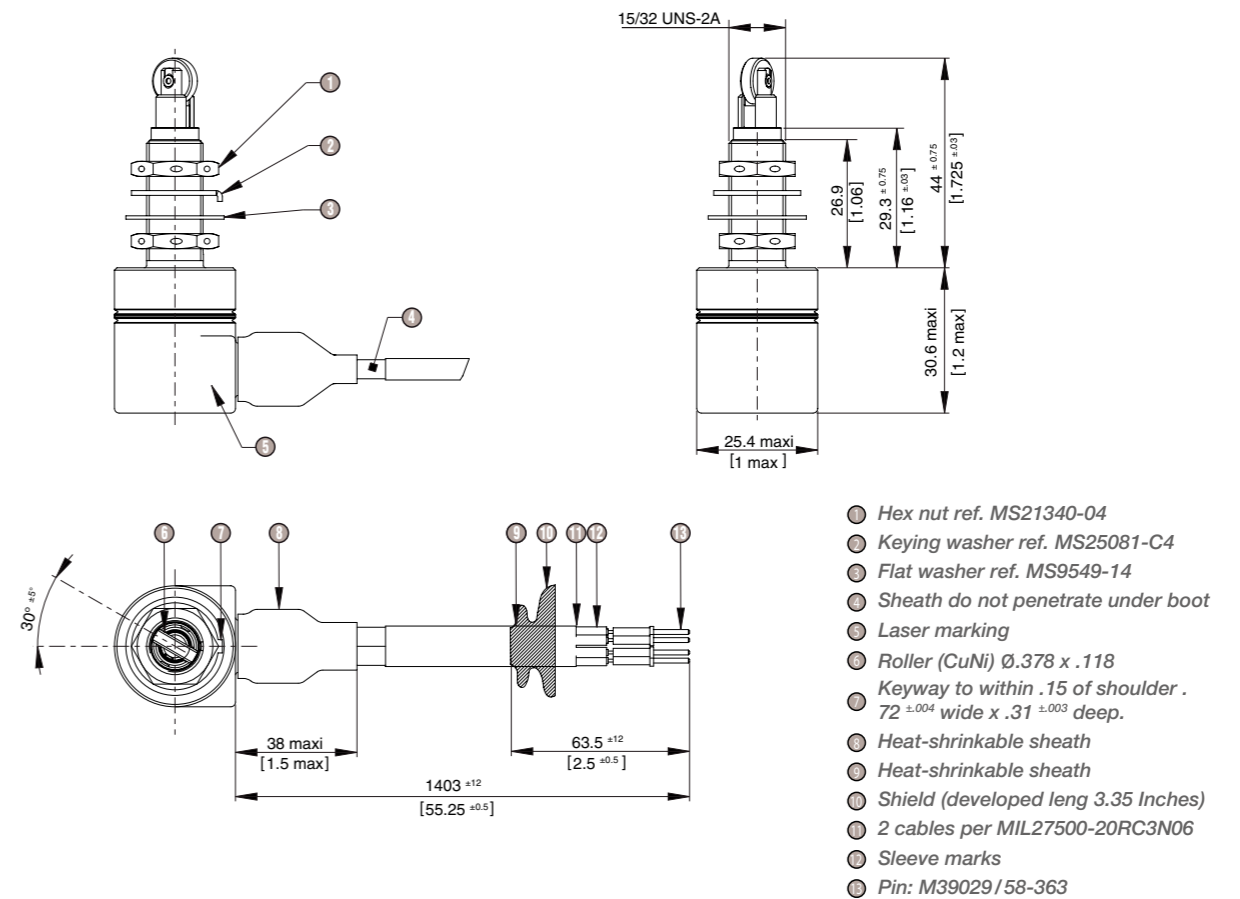

LIMIT SWITCH

FOR THRUST REVERSER ACTUATOR FUNCTION

Specifications

Part numbers **DDP770350**

Environment characteristics

Temperature	RTCA DO-160C (SECT.4 CAT.D3)
Temperature variation	MIL-STD-810E
Altitude	RTCA DO-160C (SECT.4 CAT.D3)
Humidity	RTCA DO-160C (SECT.6 CAT.B)
Operational shock	RTCA DO-160C SECT.7
Crash safety	RTCA DO-160C SECT.7
Vibration	RTCA DO-160C SECT.8 CURVE W
Explosion proofness	RTCA DO-160C SECT.9 CAT.E Environment II
Waterproofness	RTCA DO-160C SECT.10 CAT.R
Fluid susceptibility	RTCA DO-160C SECT.11 CAT.F SPRAY TEST
Sand & Dust	RTCA DO-160C SECT.12 CAT.D
Fungus resistance	RTCA DO-160C SECT.13 CAT.F
Salt spray	RTCA DO-160C SECT.14 CAT.S
Lightning induced transient susceptibility	RTCA DO-160D SECT.22 CAT. A4xx
Icing	RTCA DO-160C SECT.24 CAT. B



Electrical characteristics

Normal Operating voltage	28 VDC
Max. Operating voltage	32 VDC
Normal Operating current	10 mA < I < 50 mA
Max. Operating current	100 mA
Contact resistance	≤ 260 mΩ
Dielectric strength at atmospheric pressure	1 000 VRMS - 1 mA
Electrical bonding	25 mΩ between the body and the beginning of the shield under the sleeve
Insulation resistance	100 MΩ 500 VDC
Electrical Lifetime: (according to C.CT.DEF.00060.GB)	100 000 Cycles
Contact bounce: (Checked during shocks and vibrations test)	< 5 ms

Mechanical characteristics

The characteristics are given for standard temperature (23 °C) and atmospheric pressure at the sea level (760 mm Hg). Braided shield grounded to body of switch for 360°.

Operating force	6 to 12 lbs
Full overtravel force	20 lbs Max.
Release force	4 pound Min.
Pretravel	0.040 inch Max.
Differential travel	0.020 inch Max.
Overtravel	0.125 inch Min.
Operating temperature	-55 °C to +150 °C
Operating attack speeds	0.5 m/s Max.
Attack speeds permitted	0.7 m/s Max.
Mechanical lifetime (according QTP: C.CT.DCO.00060.GB)	100 000 cycles
Weight	265 g Max.

Principles

Circuit diagram (switch show in free position)

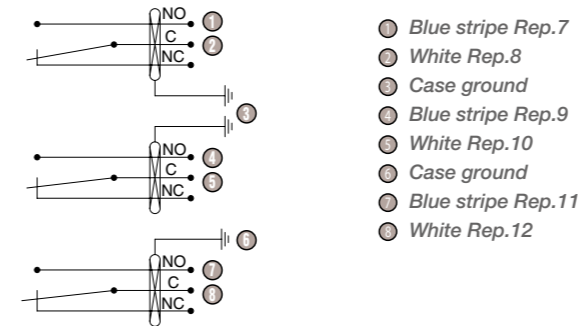

Dimensions (mm)

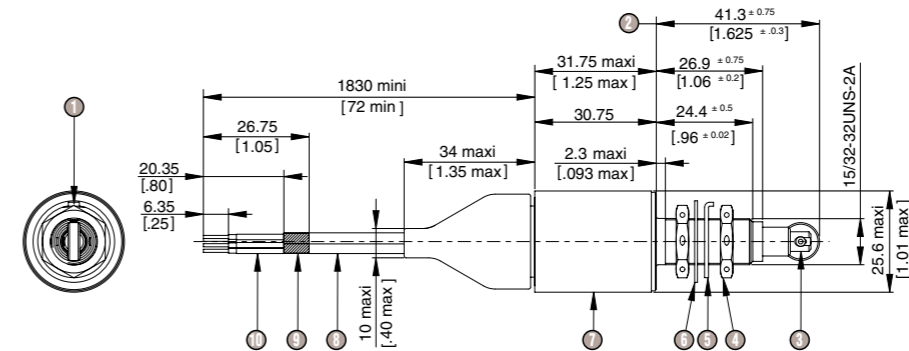

- ① Keyway to within .250 of shoulder .72 ±.004 wide x .031 ±.003 deep
Roller is aligned with keyway: ±5°
- ② Free position
- ③ Corrosion resistant material (CuNi) Ø.378 / .374 x .118
- ④ 2 x Hex nut per MS21340-04
- ⑤ 1 x Keying washer per MS25081C4
- ⑥ 1 x Flat washer per MS9549-14
- ⑦ Laser marking
- ⑧ 3 cables per MIL27500-22 RC2N06
- ⑨ Shield
- ⑩ Sleeve marks at the end of wires

LIMIT SWITCH

FOR THRUST REVERSER ACTUATOR FUNCTION



Specifications

Part numbers **DDP990175**

Environment characteristics

Operating low temperature	-67 °F
Operating high temperature	+257 °F
Number of cycles head on	80 000

Electrical characteristics

Open circuit voltage	17 VDC Max. 9 VDC Min.
Closed circuit current	2 to 20 mA

Mechanical characteristics

Max. Pre-travel	0.040 in
Max. Differential travel	0.020 in
Min. Overtravel	0.125 in
Operating force	6-12 lbs
Max. Over travel force	20 lbs

Principles

Electrical diagram (switch show in free position)

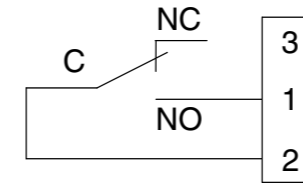

Dimensions (mm)

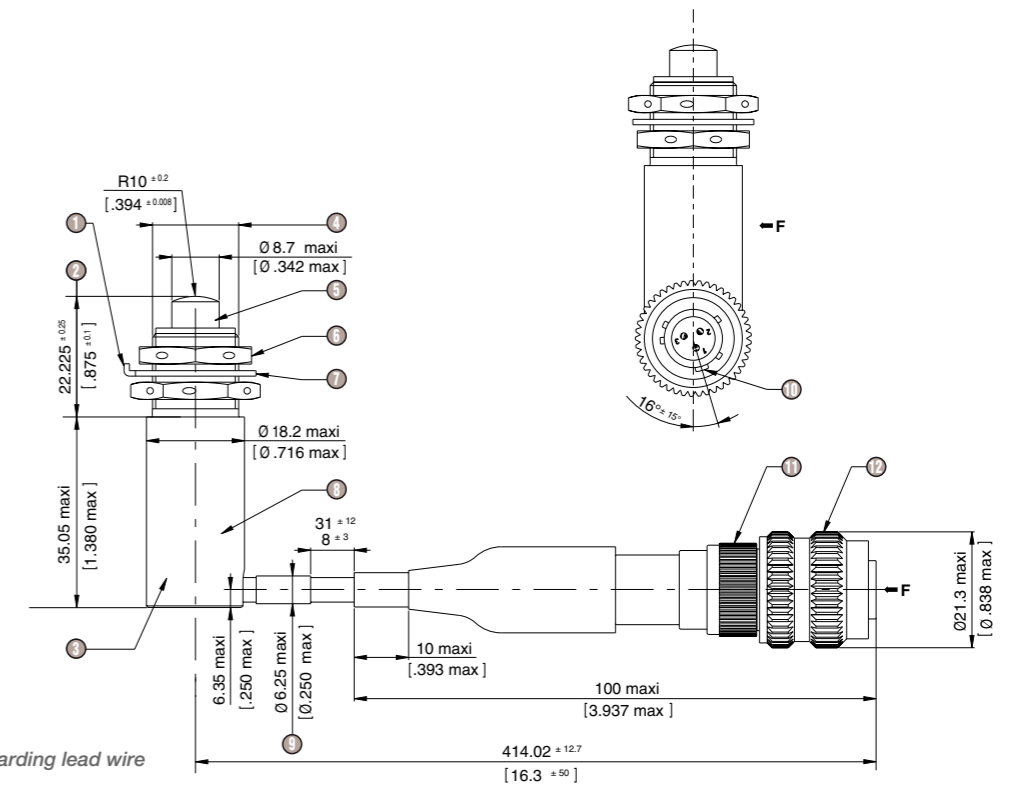

- ① Lug washer ±10° regarding lead wire
- ② Free position
- ③ Stainless steel body AISI 304L
- ④ 5/8-24 UNEF-2B
- ⑤ Stainless steel AISI 630
- ⑥ MS21340-05 nut Qty2
- ⑦ MS25081 C5 washer
- ⑧ Marking chemical etching
- ⑨ After shrinking
- ⑩ Angular position master key
- ⑪ Stainless steel with a electroless nickel finish banding backshell
Be assembled to connector with 50-60 inch Lb torque
- ⑫ Stainless steel connector EN2997-S6-08-03M6

LIMIT SWITCH

FOR THRUST REVERSER ACTUATOR FUNCTION



Specifications

Part numbers **DDP770364**

Environment characteristics

Condition	RTCA / DO-160D	
	Section	Category
Ground survival low temp. Operating low temperature	4	D3 at -67°F (-55°C)
Ground survival high temp. Short time operating high temp. Operating high temperature	4	D3 at 257°F (125°C)
Altitude		-2 000 to 41 000 ft
Temperature variation	5	A
Humidity	6	C
Operational shock	7	B
Crash shock	7	B para 7.3.2 type 2
Vibration	8	R figure 8-2, curve W with 20 G to 3 000 Hz
Explosion proof	9	E2
Waterproofness	10	S
Fluid susceptibility	11	F (COMPATIBLE WITH SKYDROL)
Sand & Dust	12	D
Fungus	13	F
Salt spray	14	S
Power input	16	B
EMI	17	A
	18	A
	19	Z
	20	V
	21	Z
Lightning	22	Level 3
	23	2A per FAA advisory circular, AC-20-136
Icing	24	B
Electrostatic discharge	25	A

Electrical characteristics

Open circuit voltage	9 to 17 VDC
Closed circuit current	2 to 20 mA
Open circuit resistance	1 MΩ min
Closed circuit resistance	10 Ω max
Bonding resistance: between connector and body contacts: gold, hermetically sealed	2.5 mΩ max
Insulation resistance: between the connector pins connected together and the case	> 100 MΩ
Dielectric strength: between the connector pins connected together and the case	l < 1 mA 500 VRMS-60 Hz/1 min

Mechanical characteristics

Number of total cycles head on	80 000
Contact speed	20 in/s Max.
Release speed	20 in/s Max.
Pre-travel	0.040 in Max.
Differential travel	0.020 in Max.
Overtravel	0.125 in Min.
Operating force	6-12 lbs
Overtravel force	20 lbs Max.
Weight	0.38 pounds Max.

Principles

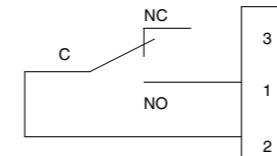

Dimensions (mm)

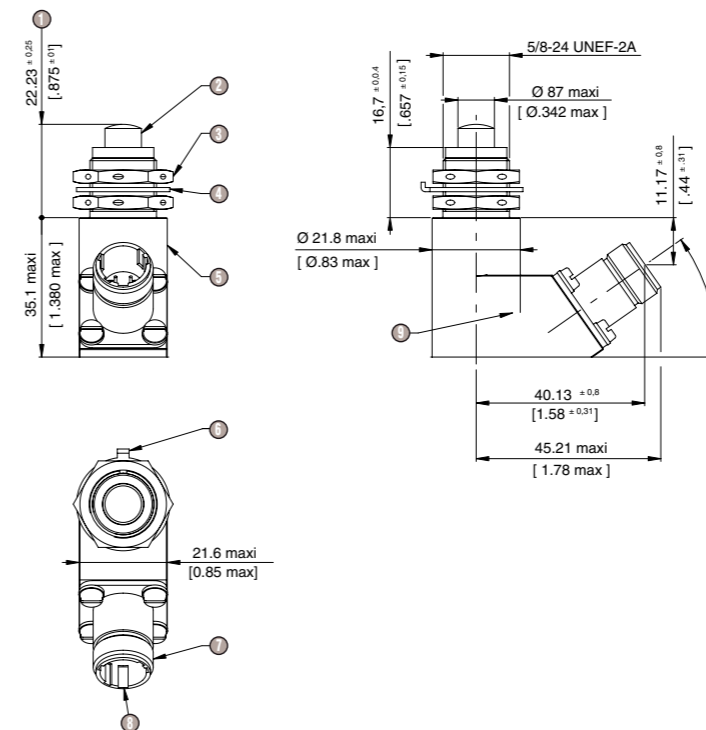

- ① Free position: 22.23^{±0.25} [0.875^{±0.01}]
- ② Stainless steel plunger
- ③ Nut Qty 2 MS21340-05 or equivalent
- ④ Locking washer MS25081 C5 or equivalent
- ⑤ Stainless steel body
- ⑥ Lug angular position: ±10°
- ⑦ Connector: EN2997-Y00803M6
- ⑧ Master keyway angular position: ±15°
- ⑨ Marking area

LIMIT SWITCH

FOR HELICOPTER FOLDING TAIL FUNCTION



Specifications

Part numbers **DDP990196**

Environment characteristics			
Condition	Normes	Method	Procedure
Temperature	MIL STD810E	501-3 502-3	I & II
Sand and Dust	MIL STD810E	510-3	
Salt fog	MIL STD810E	509-3	I
Humidity	MIL STD810E	507-3	I
Altitude	MIL STD810E	500-3	I & II
Acceleration	MIL STD810E	513-4	3.5 G/3 axis
Shocks	MIL STD810E	516-4	I
Fluid susceptibility	RS S623 A5901 E01 ISSUE A	§3332	
Vibrations	MIL STD810E	514-4	
Rain	MIL STD810E	506-3	III
E M C	N/A		
Indirect lightning	N/A		
Induced signal susceptibility	N/A		
Solar radiation	MIL STD810E	505-3	I & II

Electrical characteristics	
Rated voltage	28 VDC
Max. current (Resistive)	4 A
Max. current (Inductive)	2 A
Insulation resistance	≥ 100 MΩ

Mechanical characteristics	
Forces and travels for altitude from -150m to 4000m and for operating temperature	
Max. Operating force	25 N
Min. Release force	5 N
Max. Pre-travel	0.5 mm
Max. Differential travel	0.05 mm
Min. Overtravel	3 mm
Operating temperature	-55 °C to +90 °C
Weight	245 g max
Attack angles	25° max
MTBF	5000 Fh

Principles

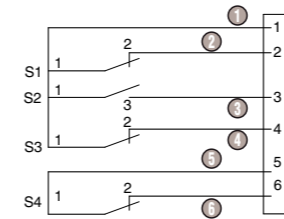

- ① Common
- ② NC Folded / Unfolded position
- ③ NO Tail in position
- ④ NC Tail out position
- ⑤ Common
- ⑥ NC Unfolded position

Dimensions (mm)

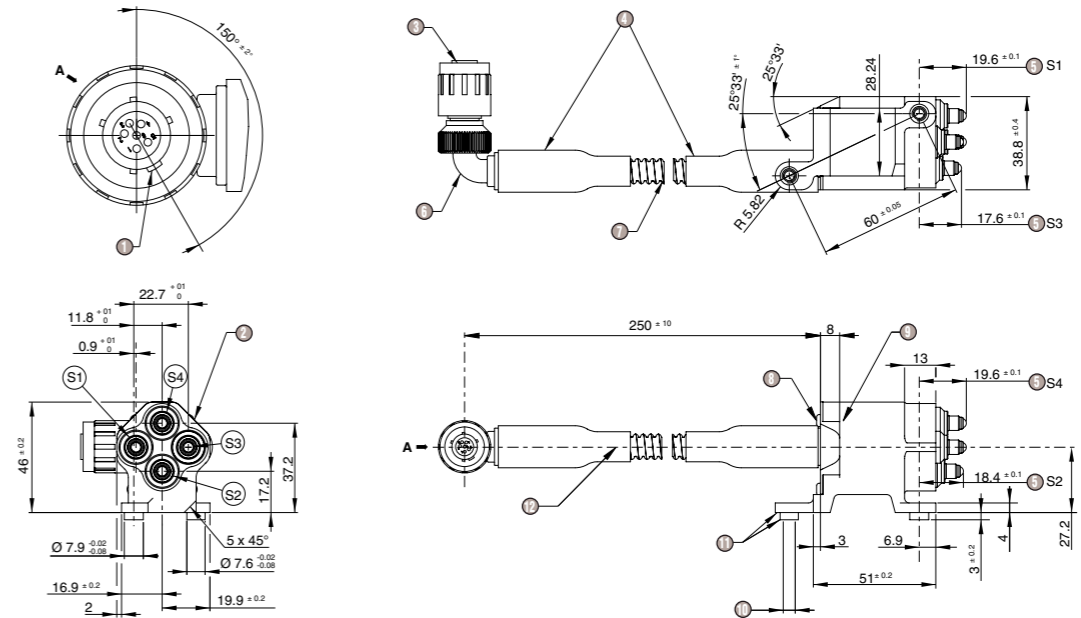

- ① Master keyway
- ② Body and cap 6061 ASN
- ③ Connector E0545J09-35XC
- ④ Boot VG95343T18A001A (202K132-25 / 225-0)
- ⑤ Si tripping point
- ⑥ 90° elbow union E0762W09-05BS
- ⑦ Flexible helicol ETFE tubing ASNE0637A08
- ⑧ 4 CBL «TORX» screws (bichromate steel)
- ⑨ Marking location
- ⑩ Heli-coil type screw lock M5
- ⑪ 1 face and 1 ø protection Alodine 1200
- ⑫ 6 AIR 1710-04 AWG 22 wires

LIMIT SWITCH

FOR THRUST REVERSER DOOR UPPER SECONDARY LOCK FUNCTION



Specifications

Part numbers **DDP770353**

Environment characteristics		
Condition	RTCA/DO-160D	Requirements
Equipment intended for installation in powerplant	Section 4.3	Category D3
Operating low temperature	Section 4	Category D3 -40 °C
Operating high temperature	Section 4	Category D3 +135 °C
Short time operating high temperature	Section 4	Category D3 +135 °C
Ground survival low temperature	Section 4	Category D3 -62 °C
Ground survival high temperature	Section 4	Category D3 +85 °C
Altitude	Section 4	Category D3 45000 ft
Temperature variation	Section 5	Category A
Humidity	Section 6	Category B
Operating shock	Section 7	Category B
Crash shock	Section 7	Category B
Vibrations	Section 8	Category H2
Explosion	Section 9	Category E2
Waterproofness	Section 10	Category R
Fluid susceptibility	Section 11	Category F spray test
Sand and Dust	Section 12	Category D
Fungus resistance	Section 13	Category F
Salt spray	Section 14	Category S
Lightning induced transient susceptibility	Section 22	Category A4XX
Icing	Section 24	Category B

Electrical characteristics	
Normal operating voltage	28 VDC
Maximum operating voltage	32 VDC
Normal operating current	10 mA < I < 50 mA
Maximum operating current	100 mA
Resistance of contact	85 mΩ Max.
Dielectric withstanding at atmospheric pressure	1 000 V rms 1 mA
Electrical bonding	2.5 mΩ between the bush and the beginning of the shield under the sleeve
Insulation resistance	100 MΩ 500 VDC
Electrical lifetime	100 000 cycles
Contact bounce (checked during shocks and vibrations tests)	< 5 ms

Mechanical characteristics	
The characteristics are given for standard temperature (23 °C) and atmospheric pressure at the sea level (760 mm hg). Braided shield grounded to body of switch for 360°.	
Operating force	to be less than 12 lbs
Pre-travel	0.04 inch max
Differential travel	0.02 inch max
Overtravel	0.125 inch min
Mechanical lifetime	100 000 cycles
Weight	120 g Max.
Operating attack speeds	0.5 m/s Max.
Outstanding max. attack speeds permitted	0.7 m/s
Product sealing	Watertight
Cell sealing	Hermetic

Principles

Circuit diagram (switch show in free position)

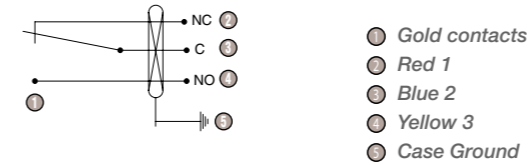

Dimensions (mm)

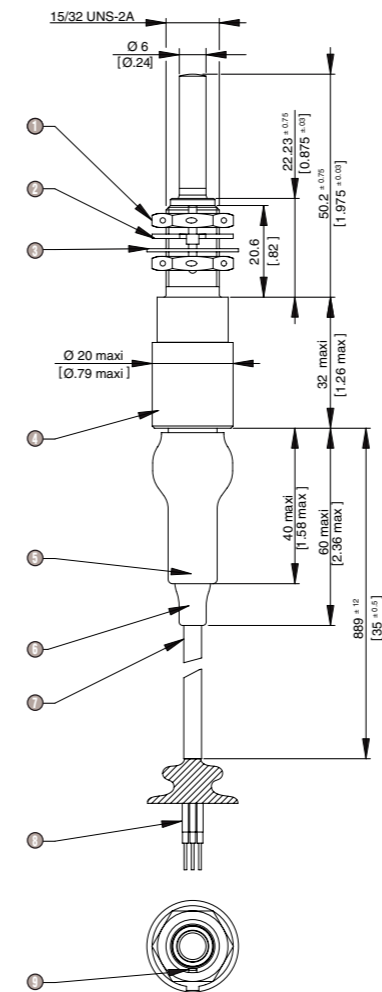

- ① Hex nut MS21340-04
- ② Keying washer MS25081-C4
- ③ Flat washer MS9549-14
- ④ Laser marking
- ⑤ Heat-shrinkable boots
- ⑥ Sleeve DR25
- ⑦ 1 cable per MIL27500-20RC3N06
- ⑧ Sleeves marks
- ⑨ Keyway to within .072 ±.004 wide X .031 ±.003 deep.

ELECTRONIC POSITION DETECTORS

2 parts proximity sensor



Proximity sensor without electronic



Remote electronic

IN ALL CASES, CROUZET WILL FIND A WAY!

with Crouzet's expertise in mechanical position detectors, Crouzet offers a range of standards product, but has the ability and capacity to develop specific components, entirely adapted to the application into its environment.

Today, Crouzet is a market leader in this technology.

PROXIMITY SWITCHES:

- › Contactless detection with integrated electronics
- › 2, 3 wires or connector output
- › Full hermetic stainless steel housing
- › Possibility of multiple output, BIT, high pressure, extended temperature range...

We create the product fully customisable dedicated to your need.

1 piece proximity switches



Proximity switches with integrated electronic

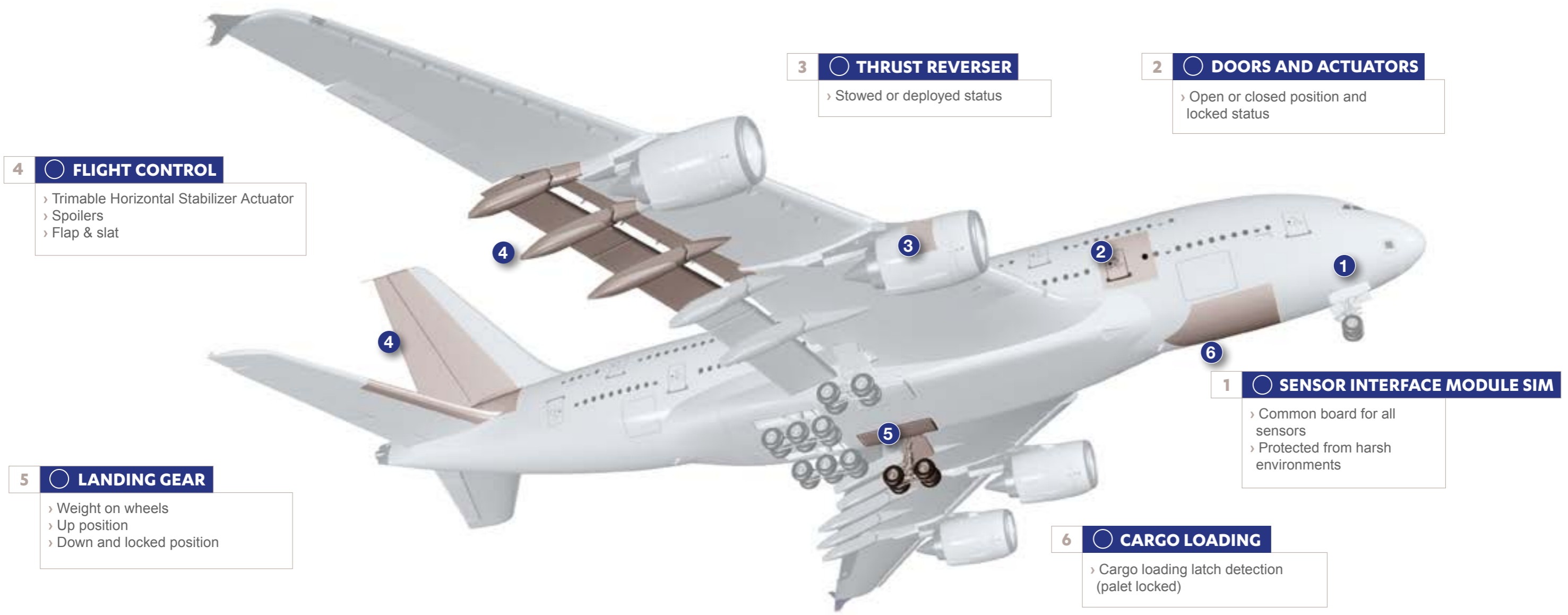

4 FLIGHT CONTROL

- › Trimable Horizontal Stabilizer Actuator
- › Spoilers
- › Flap & slat

3 THRUST REVERSER

- › Stowed or deployed status

2 DOORS AND ACTUATORS

- › Open or closed position and locked status

5 LANDING GEAR

- › Weight on wheels
- › Up position
- › Down and locked position

1 SENSOR INTERFACE MODULE SIM

- › Common board for all sensors
- › Protected from harsh environments

6 CARGO LOADING

- › Cargo loading latch detection (palet locked)

DETECTION PRINCIPLE FOR PROXIMITY SWITCHES AND TWO PARTS SENSORS

A proximity switch is a device detecting, without any physical link, a metallic part that enters a predefined space in front of it.

The sensing chain is composed of a sensing element, an electronic board and a moving part, called a target. The electronics applies a variable current in the sensing element, what creates a magnetic field around the sensing element. When the target enters the magnetic field, it changes the electromagnetic properties of the sensor which will lead to the change of one or several parameters of the current or the voltage of the coil (amplitude, frequency, phase lag, response time ...). Any variation over a threshold will set a binary signal which indicates that the target has entered a predefined space.

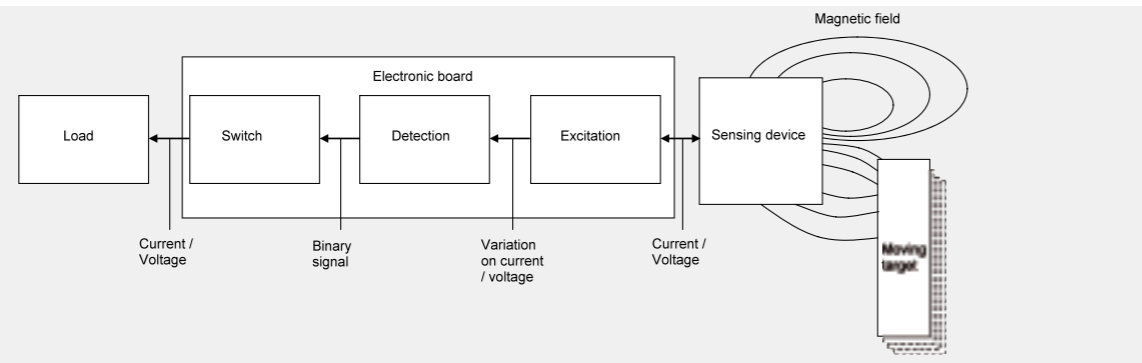

Figure 1 Measurement chain

PRODUCT INTEGRATION

The sensing device and electronic board can be integrated into one product called an active one-piece proximity switch. Such a product can be used in place of mechanical switches to detect parts that have short displacements or when there is little room to install a sensor.

When the usage conditions are harsh and when a very high MTBF is critical, sensing device and electronic board should be separated. The electronic board will be put in a protected area, typically inside a control box within the aircraft fuselage, and linked to the sensing device with two wires. In this case, the product is called two-piece proximity sensor.

KEEP OFF ZONE

Ferromagnetic and/or conductive metallic parts are forbidden between target and sensing face when target is near. More than 25 mm (1") of free space must also be left on proximity switch sides and more than 15 mm (0.60") behind the sensing face, for nominal detection characteristics.

When target is far away from the sensing face, there is a minimum space in front of the sensing face that has to be kept free from any metallic part to prevent from any change of the detection performance of the switch. The limit of this keep off zone in front of the sensing face is defined by a half-circle of minimum 25 mm (1") of radius.

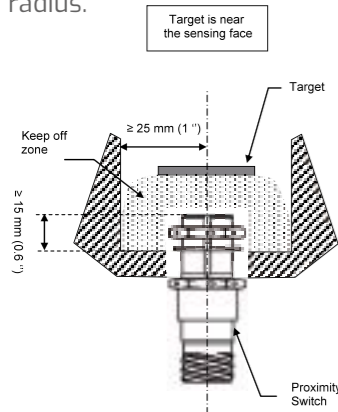

Figure 3 Keep off zone for embeddable switches

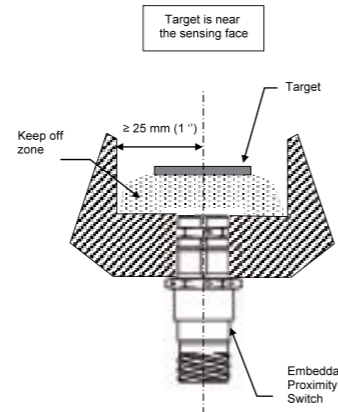

Figure 2 Keep off zone

DETECTION CURVES PRINCIPLE

Detection curves given on Crouzet datasheets are generally plotted according to the X and Z coordinates, i.e. target slide-by movement is along X axis, and gap between sensing face and target is along Z axis, assuming that proximity switch and target centres are aligned according to X-Y axis. for X-Y-Z axis definition, see figure 3. Curves are valid for a specified target, i.e. target material and dimensions.

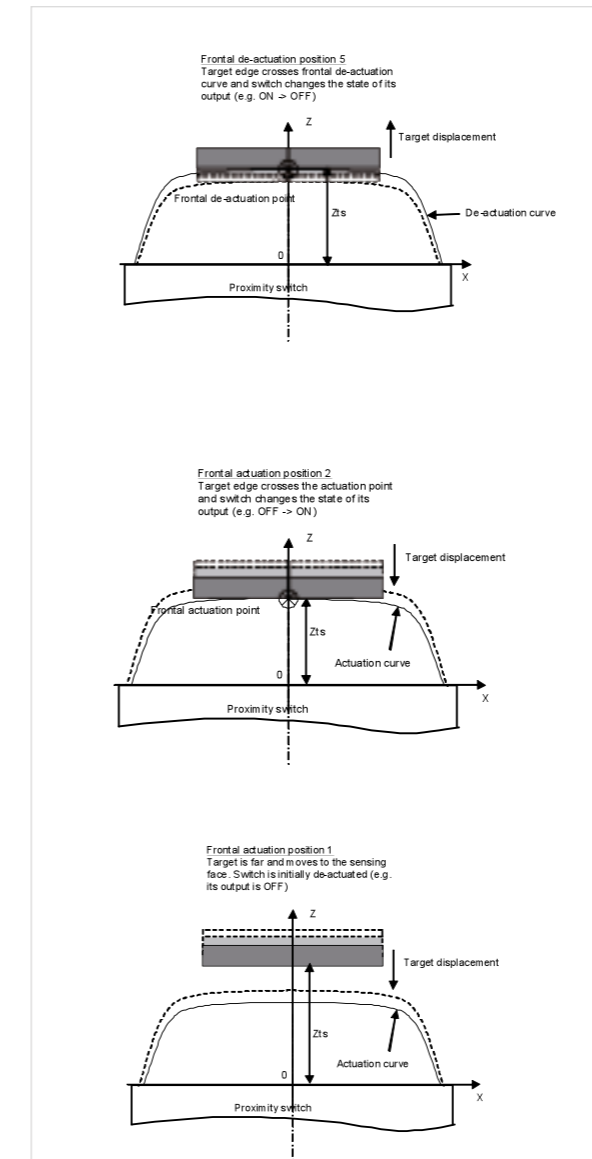

Figure 3 Target head-on actuation - deactuation point

The following sections describe the typical operating of a proximity switch according to simple target movement (slide-by and rotate-by movements), conditions on target positioning and definition, the definition of guaranteed detection curves and working zones, the constraints for target mounting, the electrical connections.

Target head-on approach

For the first "standard" movement, the head-on displacement, target and switch are centred. Target will move along the Z axis. Gap Z_{ts} is measured between sensing face of the switch and target side facing the switch.

Let target be FAR away from the sensing face and, in that case, switch de-actuated, e.g. its output being OFF if the switch is Normally Open (NO) and ON if the switch is Normally Closed (NC). When target approaches the sensing face, the switch output turns from OFF to ON (resp. ON to OFF if NC) when the gap is equal to the head-on actuation point. When target continues to approach the sensing face, the switch output remains ON (resp. OFF if NC).

Let target be NEAR to the sensing face and, in that case, switch actuated, e.g. its output state being ON (resp OFF if NC). When target moves away from the sensing face, the switch output turns from ON to OFF (resp OFF to ON if NC) when the gap is equal the head-on deactuation point. When target continues to move away from the sensing face, the switch output remains OFF (resp ON if NC).

There is a slight distance between actuation and deactuation points (for head-on or slide-by movement) which is called hysteresis. This characteristic is, generally, realised intentionally on the electronic board because it prevents random switching of the output of the sensor when target is on the detection curve and submitted to vibrations. This function can also be realised on the remote electronic board of a two piece sensor.

Hysteresis must not be confused with the grey zone. The grey zone is an area delimited by the guaranteed actuation and deactuation curves which take into account the tolerance ranges on the parts and the temperature drift of physical characteristics.

DETECTION PRINCIPLE FOR PROXIMITY SENSORS AND PROXIMITY SWITCHES

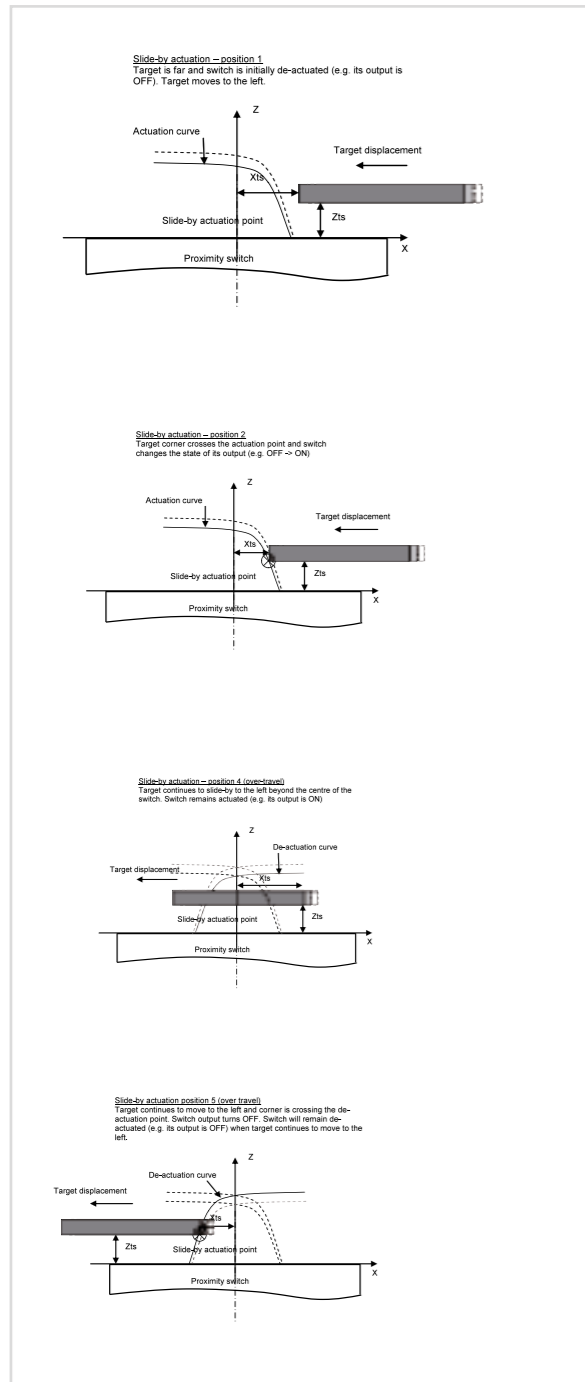

Figure 4 Slide by actuation - deactuation

Target slide-by movement

For the second "standard" movement, the slide-by displacement, target and switch Y axis are aligned, gap Z is predefined and target moves along X axis.

Let target be FAR away from the sensing face and, in that case, switch output state being OFF if switch is Normally Open (resp ON if NC). When target approaches the Z axis, the switch output turns from OFF to ON (resp ON to OFF if NC) when the lateral position is equal to the slide-by actuation point. When target continues to approach the Z axis, the switch output remains ON (resp OFF if NC).

In case of over travel (target centre crosses switch centre and continues to move), new X_{ts} coordinate have to be considered. New X_{ts} is measured between the centre of the switch and the other corner of the target.

Let target be NEAR to the Z axis and, in that case, switch output state being ON (resp OFF if NC). When target moves away from the Z axis, the switch output turns from ON to OFF (resp OFF to ON if NC) when the lateral position is equal the slide-by deactuation point. When target continues to move away from the Z axis, the switch output remains OFF (resp ON if NC).

Notice that, for a circular proximity switch and target, as long as switch front face and target face are parallel and their centres aligned, a target slide-by movement will always generate the same detection curves.

TARGET DEFINITION

In every case, target material and size are predefined on the datasheet.

The target is quite often a thin cylinder. Its diameter has to be sufficient so it will cover all the sensing face at a head-on position. Its thickness should be greater than 1 mm.

The material is generally a ferromagnetic metal. Typically it can be 17-4 PH or 15-5 PH stainless steel.

Other metals can be used, some of them as anti-target.

Target might also be rectangular, square, cylindrical, narrow or tall. It could rotate-by or have a complex movement. Shape and movement of the target will change detection curves. for any particular case, Crouzet can calculate and provide the relative detection curves.

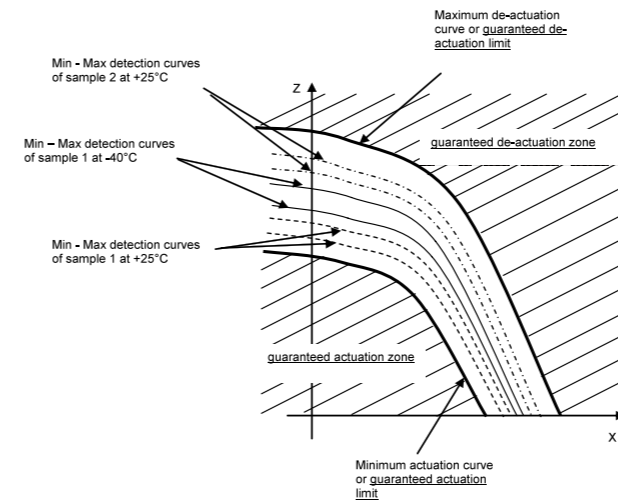

Figure 5 Definition of guaranteed detection curve and zones

GUARANTEED DETECTION CURVES

A proximity switch is a Line Replaceable Unit. to be sure to have the same sensing performance when a switch is replaced by another, a statistic study is made to determine the guaranteed detection curves applicable to any product. Typical actuation and deactuation curves deviate according to parameters of influence such as the tolerance on parts of the product, the temperature drift of the detection characteristics, the performance of the manufacturing process. As shown on the following figure, the cumulating of uncertainties induces larger distances between guaranteed actuation and deactuation points than for the typical curves. However the detection curves of a switch will always be inside the guaranteed curves.

ELECTRICAL OUTPUT CONNECTIONS FOR ONE PIECE SWITCH

Connection of Crouzet one-piece proximity switches can be shielded and twisted 3 wires (supply, ground and output) or 2 wires ("hot" input, ground) cable.

For an efficient EMI protection, back-shell termination must be shielded over 360°. Pigtail termination should be avoided. Also available are proximity switches which have two or three electrically isolated outputs.

Three wires connections

For the 3 wires configuration, the load can be connected between supply and output (sinking) or between output and ground (sourcing).

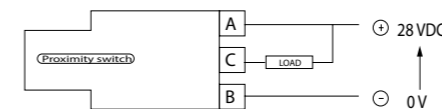

Figure 7 Load sinking (NPN)

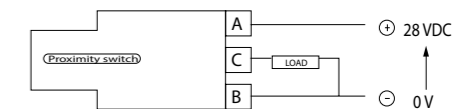

Figure 8 Load sourcing (PNP)

Two wires connection

For the 2 wires configuration, the "hot" input has two functions: first it provides the power supply to the PCB and second it controls the current through the load connected in series between the network and the "hot" input.

ELECTRICAL OUTPUT CONNECTIONS FOR A TWO PIECES SENSOR

Connection between sensing device and electronic board has to be done with a twisted pair cable. for harsh EMI environment, the cable should be shielded.

For an efficient EMI protection, back-shell termination must be shielded over 360°. Pigtail termination should be avoided.

PROXIMITY SENSOR

ROUND PASSIVE SENSOR FOR LANDING GEAR FUNCTION



Specifications

Part numbers **DPI798015**

Environment characteristics	
Operational explanations and conditions of use	C.CT.SAV.00056.GB
Environmental condition according to	DR72694
Proximity sensor mass	≤ 50 g
Housing body material	ASTM A838 alloy 2 ferritic stainless steel
Housing front face material	AISI 316L
Connector	D38999/25YA98PN matches with plug D38999/26KA98SN
Operational temperature	-55 °C to +70 °C
Survival temperature	-55 °C to +85 °C
Inductances defined @ 1 000 ±10 Hz 20 mA ±0.2 mA	
Inductance for target near	>24.53 mH @ Ga = 0.085 in (2.159 mm) at room temperature (25 °C)
Inductance for target far	<23.64 mH @ Gd = 0.12 in (3.048 mm) at room temperature (25 °C)
Inductance for target near	>24.23 mH @ Ga = 0.085 in, within operational temperature limit
Inductance for target far	<23.84 mH @ Gd = 0.12 in, within operational temperature limit
DC coil resistance at room temperature	70 Ω < R < 90 Ω
DC coil resistance within operational temperature limits	40 Ω < R < 120 Ω
ATP reference	C.CT.DCO.05761.GB
Insulation resistance	>100 MΩ @ 500 VDC
Dielectric strength	1 500 V rms , 1 mA
Bonding	2.5 mΩ

Principles

Actuation curves

Curves are guaranteed when «keep off» requirement is met. Other cases with metal in vicinity are to be specifically studied and validated by Crouzet.

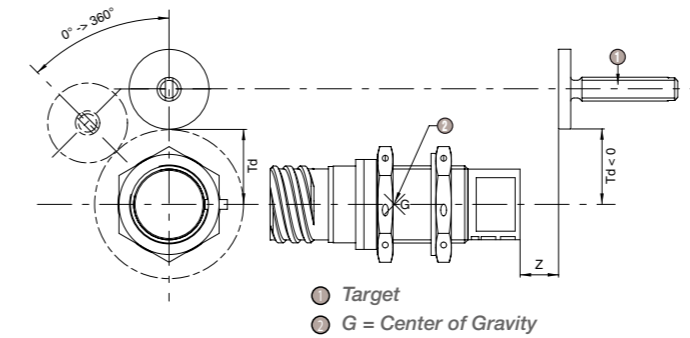
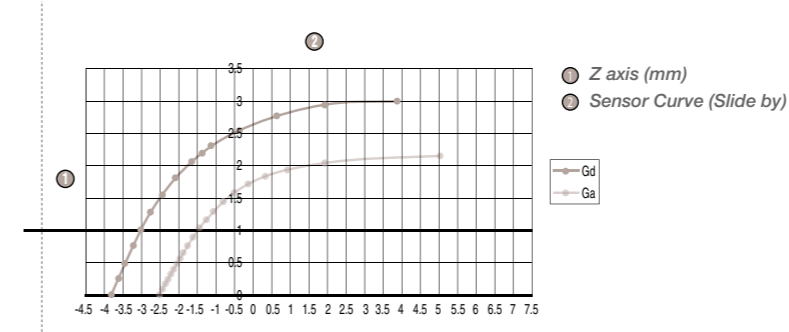

Cables and wiring

Shielded twisted pair AWG 22
Wiring external to fuselage must have 360° shield bond

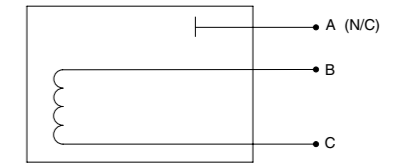

Td axis (mm)		
Z mm	Guaranted actuation gap (Ga)	Actuation curves
0	-2.49	-3.81
0.508	-2.06	-3.48
1.016	-1.47	-3.02
1.524	-0.48	-2.44
1.651	-0.13	
1.778	0.33	-2.08
1.905	0.91	
2.032	1.93	-1.65
2.159	5.08	-1.37
2.159	6.35	
2.286		-1.12
2.54		-0.43
2.794		0.64
2.921		1.91
3.048		3.81
3.048		6.35

Dimensions (mm)

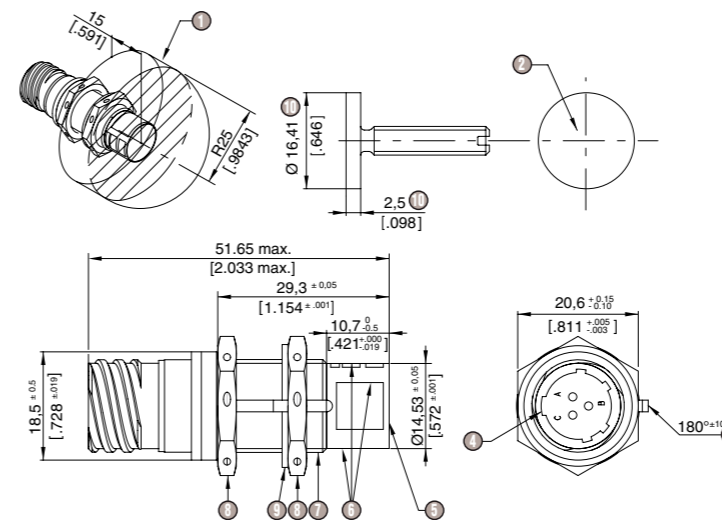

- ① Room free of metal exclusively target
- ② Laser marking
- ③ Washer nose aligned with master keyway 180°±10°
- ④ Master keyway
- ⑤ Sensing surface
- ⑥ Marking according to drawing: MA84798015
- ⑦ Thread 0.625-24 UNEF-2A
Nut MS21340-05 or Crouzet nut 79238608
- ⑧ tightening torque 70.8 Lb in / 8 Nm Max.
- ⑨ Washer key MS25081-C6 or Crouzet washer 70515367
- ⑩ Dimension critical for actuation / deactuation curves

PROXIMITY SWITCH FOR THRUST REVERSER ACTUATOR FUNCTION



Specifications

Part numbers **DPI799121**

Environment characteristics		RTCA/DO-160D	
Conditions		Section	Category
Temperature	-55 °C to +125 °C	4	F3
Temperature variation		5	A
Altitude	-2 000 to 41 000 feet	4	D3
Humidity		6	C
Waterproofness		10	R
Salt spray		14.0	S
Sand & Dust		12	D
Vibration		8	Curve W/3000 Hz
Shocks		7	A Except with 3 shocks of 6 G in each direction on each axis
Hermeticity	MILPRF8805E Watertight		
Supply voltage		16	A
Voltage spike		17	A
EMI	Conducted susceptibility	18	A
	Induced signal susceptibility	19	Z
	HIRF	20/20-5	Cat V
	Emission of radio frequency energy	21	H
Explosion proof		9.0	Environment 11
Fluids susceptibility	SKYDROL	11.0	F
Fungus		13.0	F
Magnetic effects		-	N/A
Lightning indirect effect	Pin injection	22	Power: L4 waveform 5A Signal: L3 waveform 4
Sustained acceleration		7	Procedure type R
Electrostatic discharge		25	H

Electrical characteristics	
Function	Normally open When target is far, the output is not conductive When target is near, the output is conductive
Temperature	Operating: -55 °C, +125 °C Storage: -65 °C, +125 °C
Detection	Target: 19.05mm (0.75 IN) diameter 1.78mm (0.07 IN) thickness material 15-5 PH Slide by detection for a gap = 2.03 mm (0.08 IN) Differential travel: 1.02 mm max (0.04 IN) Shift actuation and deactuation point (temperature and supply variations): 0.51 mm (0.02 IN)
Supply voltage	16 V Min., 32.5 V Max., 28 VDC per MIL-STD-704
Max. Consumption current	10 mA Max. under 32.5 V
Output voltage	8 VDC Min., 32.5 VDC Max.
Output leakage voltage (target near)	1.5 V Max. under 25 mA
Output leakage current (target far)	100 µA Max.
Output current max. 25 mA	Resistive or Inductive Maximum switching frequency: 50 Hz
Protections	Against inversion supply polarity and output polarity with load Against permanent short circuit of the load
Dielectric test	ISO 2678 Category C Dielectric strenght: 750 VAC/50 Hz - 1 min - 1 000 µA Insulation resistance: 100 MΩ/45 VDC Bonding resistance between connector and housing: 2.5 mΩ max
Mtbf	100 000 flight hours
Endurance	80 000 cycles at max load (50 mA)
Weight	250 g max (0.55 pounds)

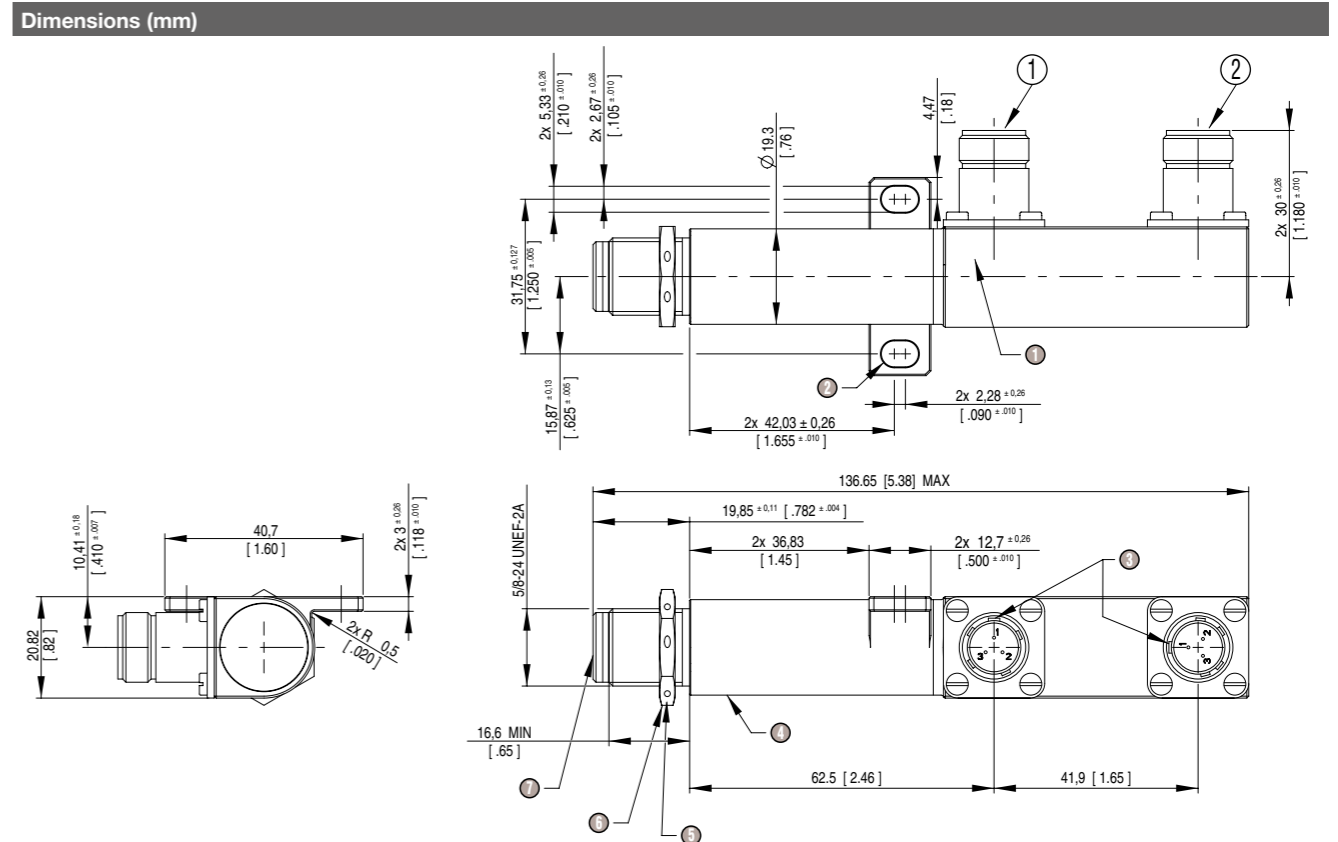
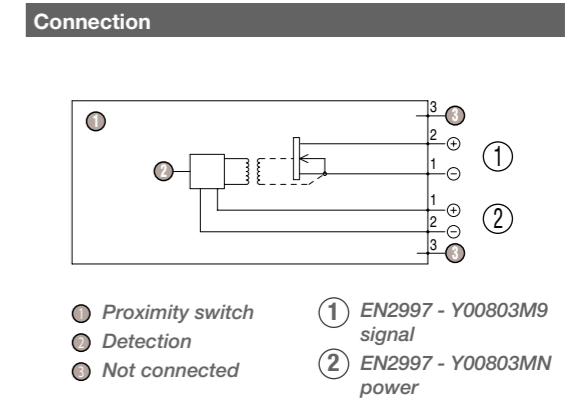
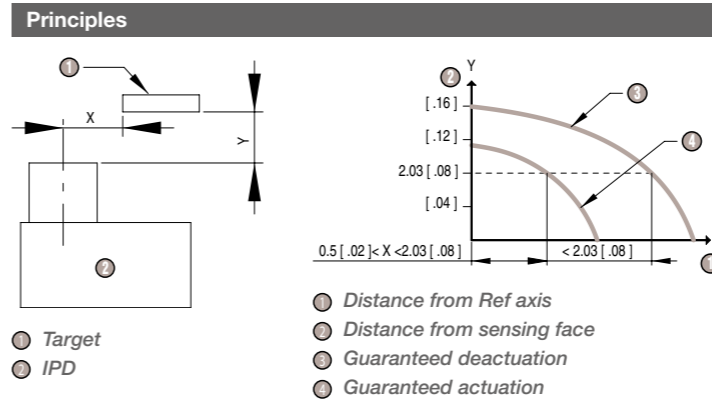

PROXIMITY SWITCH

ALL METAL FOR THRUST REVERSER ACTUATOR FUNCTION



Specifications

Part numbers **DPI799184**

Environment characteristics	
Operating temperature	-65°F to +185°F (-55°C to +85°C)
Storage temperature	-65°F to +160°F (-55°C to +71°C)
Short time operating temperature	+240°F (+116°C)/10 mn
Altitude	RTCA DO-160D Section 4.6.1 Category D3
Humidity	RTCA DO-160D Section 6 Category C
Vibration	Section 2.1 per Figure 6-1 and Figure 7-17
Acceleration	Section 4.1 Zone 9 except with 8 G's in any axis
Explosive atmosphere	RTCA DO-160D Section 9 Category H
Waterproofness	RTCA DO-160D Section 10 Category S
Fluid susceptibility	Resistant to MIL-L-7808 & MIL-L-23699
Sand & Dust	RTCA DO-160D Section 12 Category D
Fungus	RTCA DO-160D Section 13 Category F
Salt spray	RTCA DO-160D Section 14 Category S
Icing	RTCA DO-160D Section 24 Category A
Material	Stainless steel including front face
Tightening torque	88 in.Lb (10 Nm) Max.
Weight	3 oz (85 g) Max.
Mtbf	400 000 Fh

Electrical characteristics	
Supply	15 VDC ±10%
Maximum voltage	16.5 VDC
Magnetic effect	RTCA DO-160D Section 15 Category A
Voltage spike	RTCA DO-160D Section 17 Category A
Electromagnetic emissions	Section 8 Category 4
Electromagnetic susceptibility	Section 7 Category 4
HIRF	RTCA DO-160D Category R
Lightning effects	Section 7.4 Level L2
Electrical continuity	2.5 mΩ Max. between case and connector
Leakage current	50 μA Max. at 16.5 VDC
Switching response time (Ton & Toff)	5 ms Max.
Switching frequency	100 Hz Max.
Insulation resistance	100 MΩ/500 VDC
Dielectric strength	1 000 VAC/50 Hz/1 mA
Protection against	Polarity inversion and load short circuit

Principles

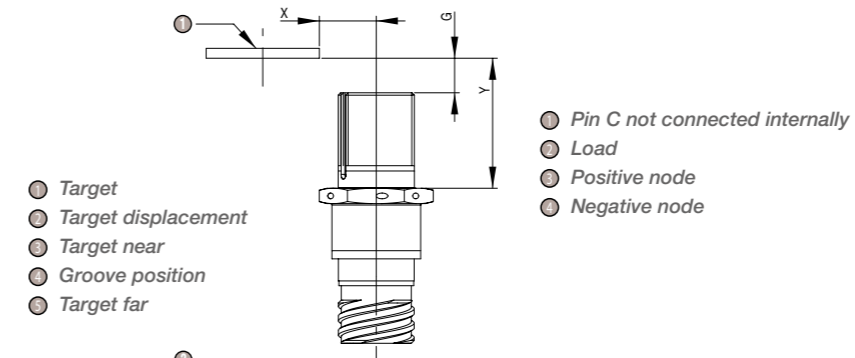
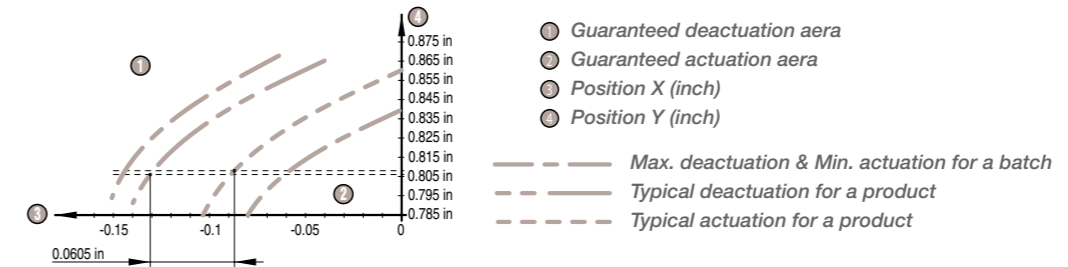

Connection

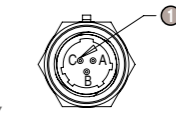

Wiring diagram

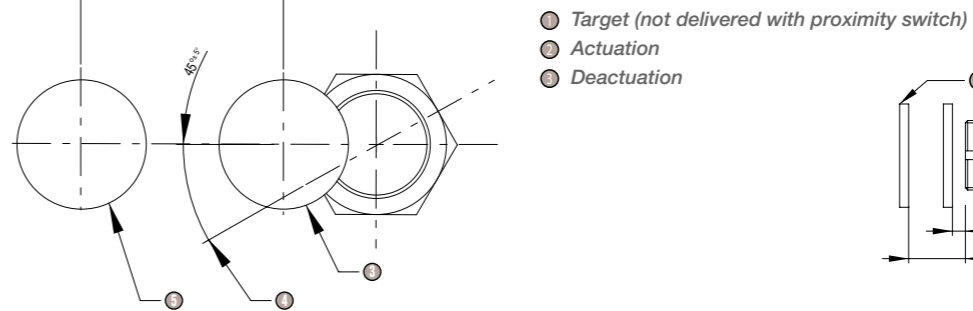
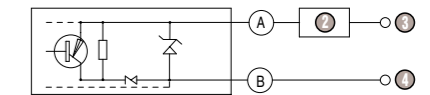

Dimensions (mm)

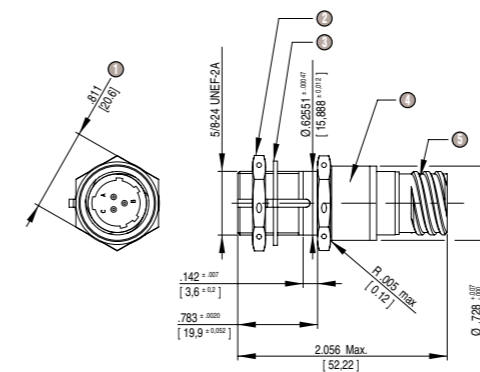

PROXIMITY SWITCH FOR LANDING GEAR FUNCTION



Specifications

Part numbers **DPI799153**

Environment characteristics

Condition	RTCA / DO-160E	
	Section	Category
Temperature & altitude	4	D2 & 4.6.1
Temperature variation	5	A
Humidity	6	C
Waterproofness	10	S
Icing	24	B
Salt spray	14	T & 14.3.6.7
Sand & Dust	12	S 12.4 & 12.5
Vibration	8	R & H Curves E, E1 & P
Shocks	7	7.2
Fungus	13	F
Fluids susceptibility	11	F
Power input supply DC	16	B
Voltage spikes	17	A
Magnetic effects	15	A
Radio frequency susceptibility	20	A & F
Lightning induced transient susceptibility	22	A4G44
Conducted susceptibility audio frequency	18	Z
Induced signal susceptibility	19	ZC
Emission of radio frequency energy	21	H
Electrostatic discharge	25	A
Crash safety shock	7	7.3.1 & 7.3.3

Electrical characteristics

Temperature operating	-55°C to +95°C
Temperature survival	-61°C to +95°C
Supply Min.	16 V
Supply Max.	32.5 V
Current consumption	10 mA Max. under 32.5 V
Leak voltage	1 VDC under 250 mA
Leakage current	50 mA Max.
Max. Load	250 mA Resistive, 125 mA Inductive, 40 mA Lamp
Electrical continuity	< 2.5 mΩ
Dielectric strenght	1 000 VDC/1 mA
Insulation resistance	100 MΩ/45 VDC
Protections	Against inversion of polarity Against permanent short circuit of the load
Switching frequency	50 Hz Max.
Power on reset time	Tp ≤ 15 ms
Weight	45 g Max. without nuts & washer
Tightening torque	20 Nm Max. (176 in.Lb)
Connector to wrenching flats torsional load	5 Nm Max. (44 in.Lb)

Principles

Connection

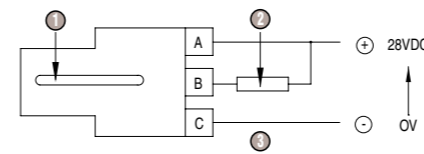

- ① Proximity Switch
- ② Load
- ③ Output: NPN type

Detection characteristics

Target: ferro magnetic material
(ex: 17.4 PH annealed)
Ø 0.625 in (15.87 mm) thickness ≥ 1 mm

Frontal approach	Operating-Temperature	-55°C to +95°C
Target approaching	Minimum actuation	0.12 (3.05 mm)
Target receding	Maximum actuation	0.16 (4.06 mm)
	Maximum Hysteresis	0.015 (0.38 mm)

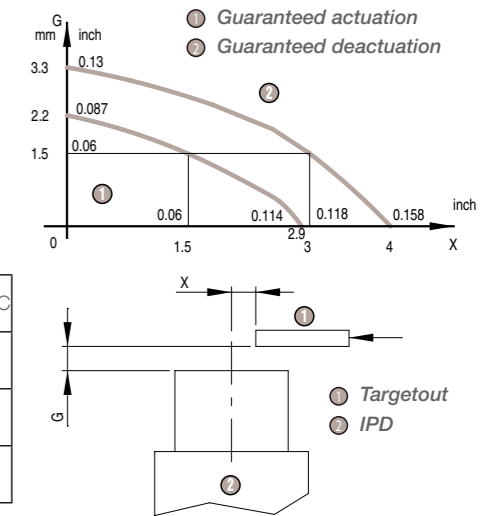

Dimensions (mm)

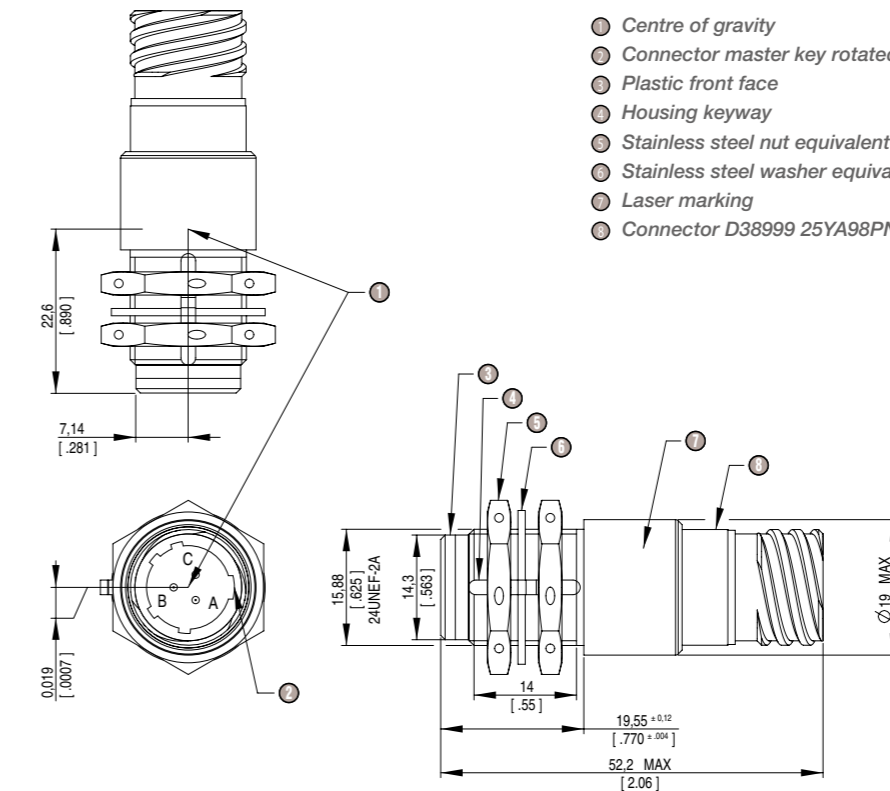

- ① Centre of gravity
- ② Connector master key rotated 180 ±5° from housing keyway
- ③ Plastic front face
- ④ Housing keyway
- ⑤ Stainless steel nut equivalent to MS21340-05
- ⑥ Stainless steel washer equivalent to MS25081-C6
- ⑦ Laser marking
- ⑧ Connector D38999 25YA98PN mates with D38999 26JA98SN

PROXIMITY SWITCH

ALL METAL FOR LANDING GEAR FUNCTION



Specifications

Part numbers **DPI799118**

Environment characteristics	
Operating temperature	-55°C to +75°C
Survival temperature	-55°C to +85°C
Altitude	RTCA DO 160D Section 4 Category F2 (Max. Operating altitude 51 000 ft)
Overpressure	RTCA DO 160D Section 4 (absolute pressure 180 Kpa)
Temperature variation	RTCA DO 160D Section 5 Category B
Shocks & Crash safety	RTCA DO 160D Section 7 § 7.2 & § 7.3
Humidity	RTCA DO 160D Section 6 Category B
Sand and Dust	RTCA DO 160D Section 12 Category D
Fungus	RTCA DO 160D Section 13 Category F
Salt spray	RTCA DO 160D Section 14 Category S
Waterproofness	RTCA DO 160D Section 10 Category W
Vibrations	RTCA DO 160D Section 8 Category S (Curve E)
Material	Stainless steel including front face
Weight	70 g Max. (2.5 Oz)
M T B F	400 000 H

Electrical characteristics	
Supply	+28 VDC
Minimum voltage	17 VDC
Maximum voltage	32.5 VDC
Power input test	RTCA DO 160D Section 16 Category Z
Magnetic effect	RTCA DO 160D Section 15 Category A
Voltage spike	RTCA DO 160C Section 17 Category A
Audio frequency conducted susceptibility	RTCA DO 160D Section 18 Category Z
Audio frequency conducted audio frequency conducted	RTCA DO 160D Section 19 Category A
Radio frequency susceptibility (conducted & radiated)	RTCA DO 160D Section. 20 Category R
Emission of radio frequency energy	RTCA DO 160D Section. 21 Category M
Induced lightning strike protection	RTCA DO 160D Section. 22 Level 2
Current consumption	10 mA Maximum under 32.5 VDC
Leak voltage	1.5 VDC Maximum under 100 mA
Load current	100 mA Maximum
Switching response time (Ton and Toff)	2 ms Maximum
Switching frequency	100 Hz Maximum
Insulation resistance	100 MΩ / 50 VDC
Dielectric strength	500 VDC/1 mn/ 1 mA
Protection against	Polarity inversion and load short circuit

Principles

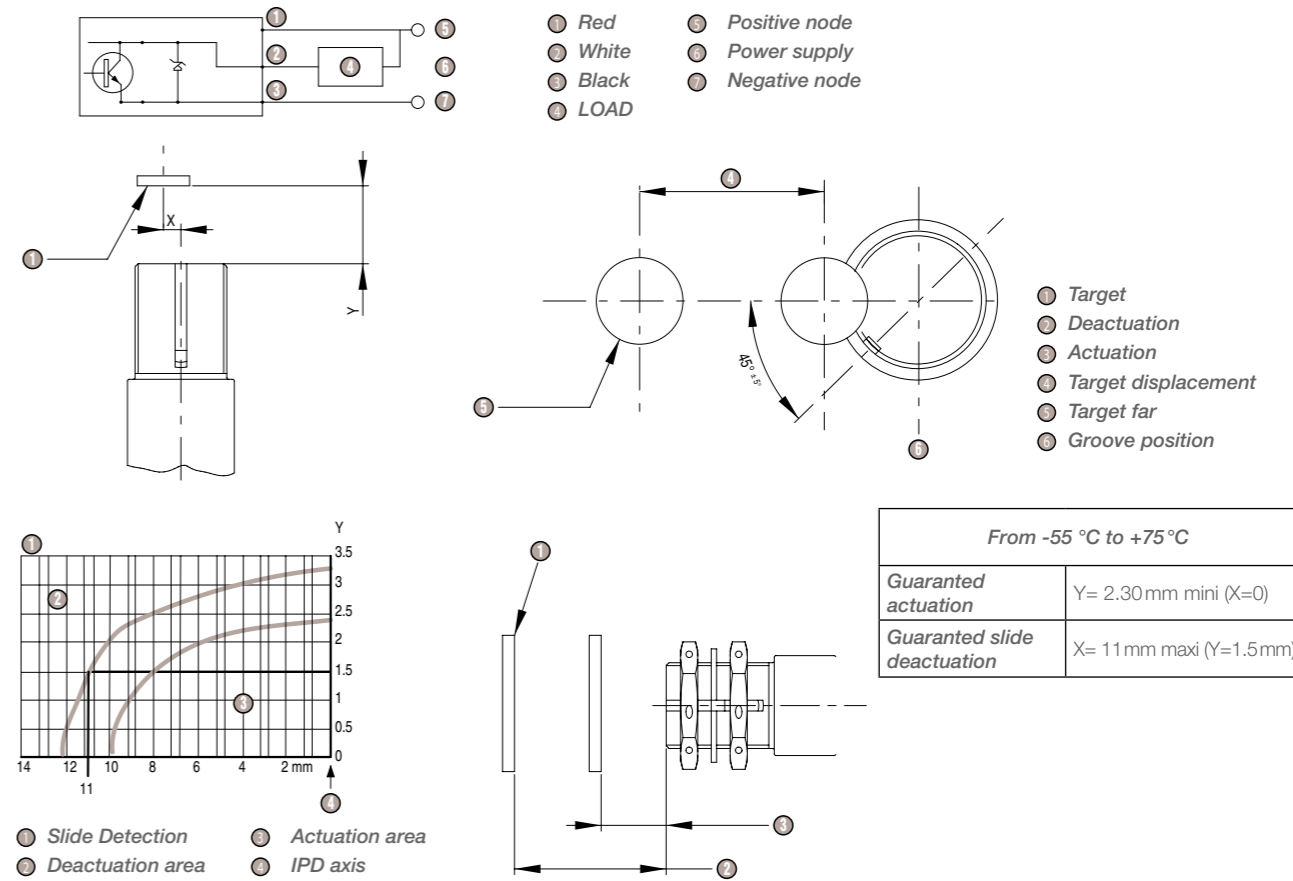

Dimensions (mm)

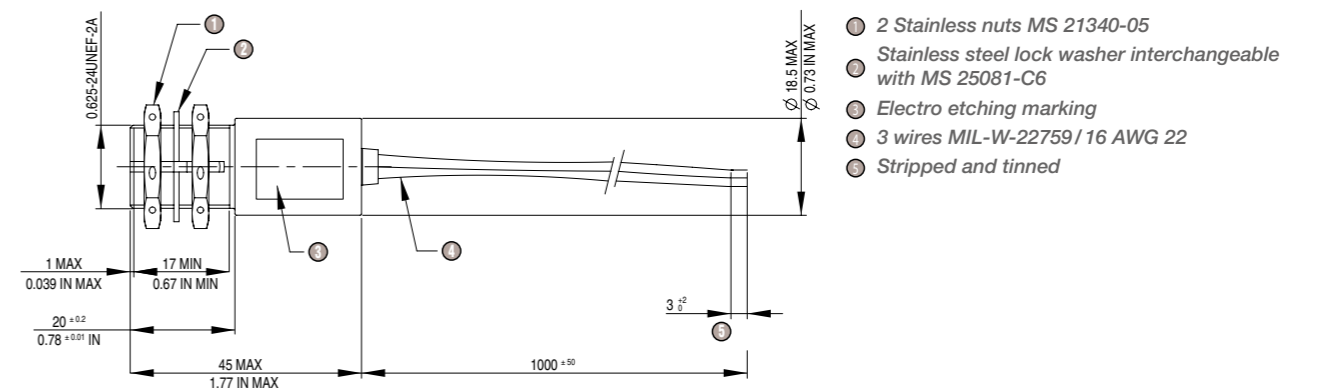

PROXIMITY SWITCH

HIGH PRESSURE FOR WIND TURBINE FUNCTION



Specifications

Part numbers **DPI799061**

Environment characteristics				
Condition	A BD 0007		RTCA / DO-160C	
	Section	Category	Section	Category
Temperature	3.2	A2	4	A2
Altitude	3.3	43.100 ft -1 000 ft	4	D2
Humidity	3.4	B	6	B
Waterproofness	3.5	R	10	R
Icing	3.6			
Salt spray	3.7	S	14.3.6.6	S
Sand and Dust	3.8	D	12.3	D
Vibration	3.9	3J/C	8	J/C
Shock	3.11.1		7.1/7.2	
Accelerations	3.12	Flight max. Values		
Moisture	3.13	X	13	X
Pollution	3.14	X	11	X A/H
Dielectric strenght	2-3.7			
Power input supply DC	2-3.5		16	
EMI			19	A
Fluids susceptibility	2.3.11.3 to 2.3.11.10			

Electrical characteristics	
Temperature Operating	-55°C to +90°C
Supply Min.	14 V
Supply Max.	32.5 V
Maximum voltage drop	2 V under 150 mA 3 V under 500 mA
Maximun current	500 mA Resistive or Inductive 50 mA Lamp nominal current
Electrical continuity	Between case and connector < 8 mΩ
Dielectric test	Dielectric strenght 500 VDC Insulation resistance: 400 MΩ / 50 Volts
Current consumption	10 mA Max. under 32.5 V
Protections	Against inversion of polarity Against permanent short circuit of the load
Hermeticity	NFC 20631 Test QC Method 2
Pressure on the detection face	Normal working pressure: 206 +3 Bar
Hydraulic fluid NSA 307 110	Test pressure: 313 Bar

Principles

Function: normally open

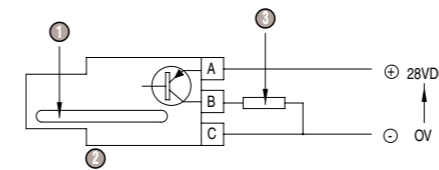

- ① Proximity Switch
- ② Output: PNP Type
- ③ Load

Frontal approach

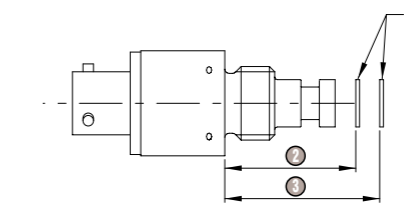

- ① Target
- ② Actuation
- ③ Deactuation

Target: 9 mm square ; 1 mm thickness
Mat 1. 4104 (AFNOR Z10CF17)
For other target material / dimension, Ga/Gd may vary.

Temperature	-55°C to +90°C	20 °C
Actuation distance	≥ 21.7 mm	≥ 21.87 mm
Deactuation distance	≤ 22.55 mm	≤ 22.3 mm

Dimensions (mm)

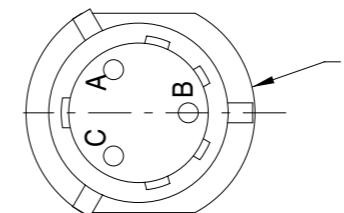
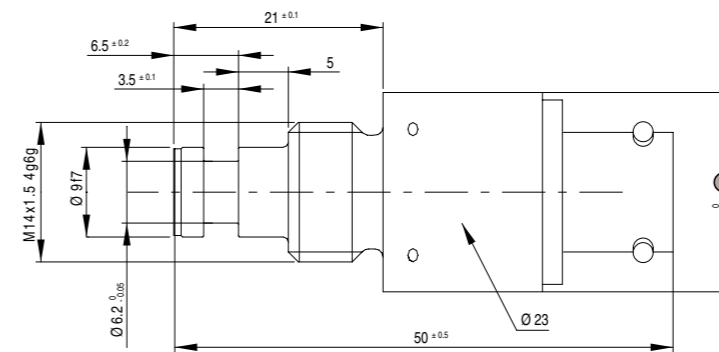

- ① Flats
- ② Connector type ASN-E0053N8B3PN

PROXIMITY SWITCH

HIGH PRESSURE FOR LANDING GEAR FUNCTION



Specifications

Part numbers **DPI799059**

	Norme MIL STD	Section Method	Procedure
Temperature	810E	501-3&502-3	1 and 2
Altitude-Pressure	810E	500-3	1 and 2
Solar radiation	810E	505-3	1 and 2
Rain	810E	506-3	1 and 3
Ice and Icing rain	810E	521-1	1
Sand and Dust	810E	510-3	1 and 2
Direct effects of lightning	1757A	ZONE 1B	Stationary impact
Vibrations	810E	514-4	1-4-2-2
Accelerations	810E	516-4	4
Load factors	810E	513-4	2
Shocks	810E	516-4	1
Crashes	810E	516-4	5
Fungus	810E	508-4	Cat.1
Conduced susceptibility	MIL STD 461-462	CS01/02/06/07	
Radiated susceptibility	MIL STD 461-462	RS01/02/03	
Conducted emissions	MIL STD 461-462	CE01/02/03/04	
Emitted spikes on power lines	Pr EN2282		
Radiated emission	RTCA DO 160C	15	Cat.Z
	MIL STD 461C	RE01-RE02	
HIRF Radiated susceptibility	MIL STD 462	RS03	
HIRF Conducted susceptibility	RTCA DO 160C	Section 20	Cat.Y
Electrostatic protection	RTCA DO 160D	25	A
Humidity test	810E	507-3	1
Salt atmosphere	810E	509-3	1

Electrical characteristics	
Operating temperature	-54 °C to +120 °C
Operating oil temperature	-54 °C to +135 °C during 4 hours Max.
Supply	14 V Min., 38 V Max.
Leak voltage	2 V under 100 mA
Current Max. 100 mA	Resistive or Inductive
Electrical continuity	Between case and connector < 2.5 mΩ
Dielectric test	Dielectric strenght 500 VDC - 1 mA
	Insulation resistance: 100 MΩ/500 V
Current consumption	15 mA Max. under 14 V
	15 mA Max. under 32.5 V
	15 mA Max. under 38 V
Protections	Against inversion of polarity
	Against permanent short circuit of the load
Pressure on the detection face	Hydraulic fluid MIL H 5606F and MILH 83282C
	Burst pressure: 518 Bar Proof pressure: 310 Bar
Connector	Type D38999 25Y A98PN
Box material	Stainless steel
Weight	120 g Max.

Principles

Function: normally open

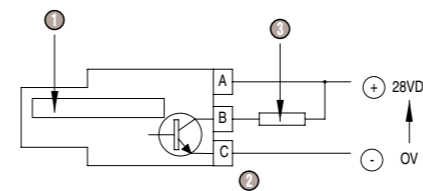

- ① Proximity Switch
- ② Output: NPN type
- ③ Load

Slide detection curve

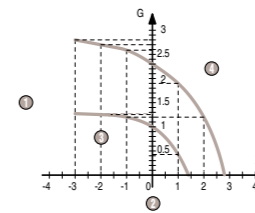

- ① Distance from sensor face (mm)
- ② Distance from center line (mm)
- ③ Guaranteed actuation
- ④ Guaranteed deactuation
- ⑤ Target

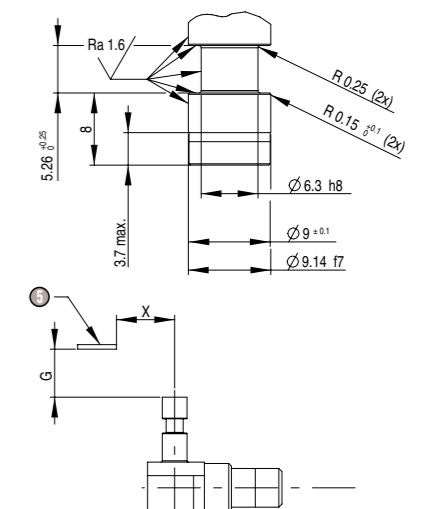

Dimensions (mm)

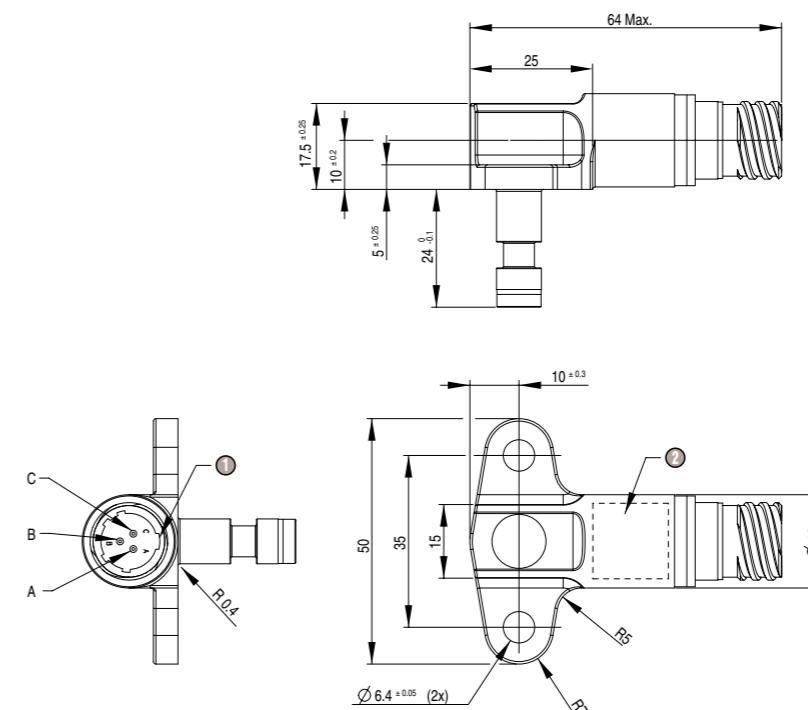

- ① Master keyway
- ② Marking area

PROXIMITY SWITCH

FOR CARGO LOADING SYSTEM FUNCTION



Specifications

Part numbers **DPI799074**

Environment characteristics

Condition	ABD 100		RTCA / DO-160D	
	Section	Category	Section	Category
Temperature	1.2.1.1	A2	4	A2
Altitude	1.2.1.2	43 100 ft -1 000 ft	4	A2
Humidity	1.2.1.4	A	6	A
Waterproofness	1.8		10	R
Icing	1.2.1.15		24	A
Salt spray	1.2.1.12		14	S
Sand and Dust	1.2.1.10		12	D
Vibration	1.2.1.6		8	S
Shocks	1.2.1.5	operational shocks	7	A 6 G/11 ms
Accelerations	1.2.1.20	Flight max. values		
Fungus	1.2.1.11		13	F
Fire class	1.2.1.17	N/A		
Fluids susceptibility	1.2.1.9		11	F
Power input supply DC	1.9		16.5	A
Voltage spikes	1.6		17	A
Magnetic effects	1.2.1.14		15	A
Radio frequency susceptibility	1.2.3.3		20	U
Lightning induced transient susceptibility	1.2		22	C
Conducted susceptibility audio frequency	1.2.3.4.2		18	A
Induced signal susceptibility	1.2.3.4.3		19	Z
Emission of radio frequency energie	1.2.3.4.4		21	L

Electrical characteristics

Temperature	Operating: -40°C to +70°C
	Survival: -55°C to +85°C
Supply	Min.: 17 V, Max.: 32.5 V
Leak voltage (target near)	0.25 V under 250 mA
Current Max. 250 mA	Resistive or Inductive
Electrical continuity	Between case and connector < 20 mΩ
	Leakage current (target far) ≤ 500 μA under 28 V
Current consumption	8 mA Max. under 28 V
	Switching frequency ≤ 100 Hz
	Insulation resistance ≥ 100 MΩ at 45 VDC
	Dielectric strenght >500 VDC
	Momentary power interruption: <1 ms
Protections	Against inversion of polarity
	Against permanent short circuit of the load
Vibration test	IPD is fixed by 2 screws

Principles

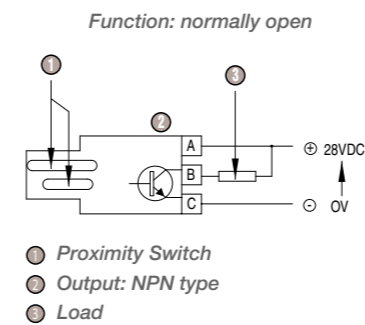

Detection characteristics

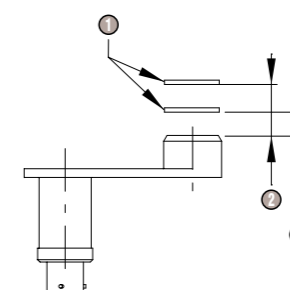

- ① Target
- ② Deactuation
- ③ Actuation

Temperature	-40°C to +70°C
Actuation distance	5 mm mini
Deactuation distance	7 mm maxi

Dimensions (mm)

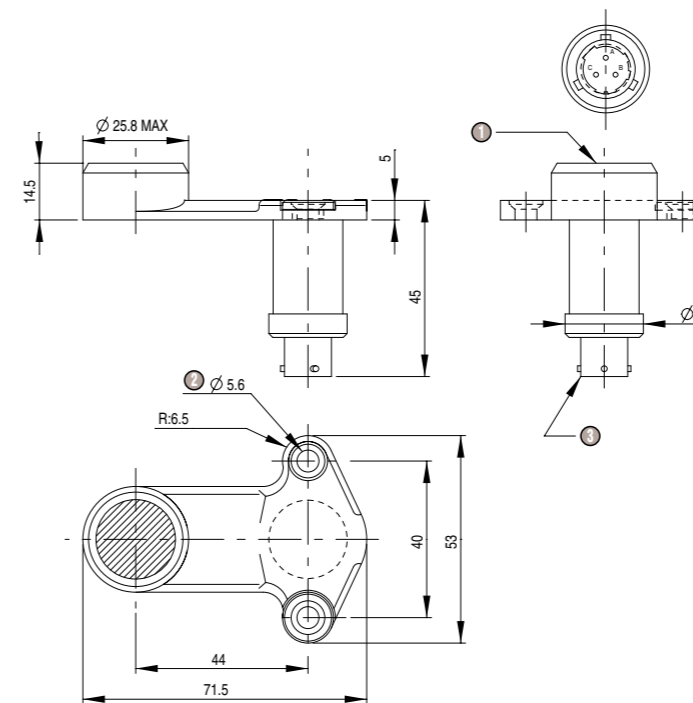

- ① Detecting face
- ② 2 holes
- ③ Connector type ASN-E0053N8B3PN

PROXIMITY SWITCH

FOR CARGO LOADING SYSTEM FUNCTION



Specifications

Part numbers **DPI799116**

Environment characteristics				
Condition	ABD 100 Section	Category	RTCA / DO-160D Section	Category
Temperature	1.2.1.1	A2	4	A2
Altitude	1.2.1.2	-1 000 ft +43 100 ft	4	A2
Humidity	1.2.1.4	A	6	A
Waterproofness	1.8		10	R
Icing	1.2.1.15		24	A
Salt spray	1.2.1.12		14	S
Sand and Dust	1.2.1.10		12	D
Vibration	1.2.1.6		8	S
Shocks	1.2.1.5	Operational shocks	7	A 6 G/11 ms
Accelerations	1.2.1.20	Flight max. values		
Fungus	1.2.1.11		13	F
Fire class	1.2.1.17	N/A		
Fluids susceptibility	1.2.1.9		11	F
Power input supply DC	1.9		16.5	A
Voltage spikes	1.6		17	A
Magnetic effects	1.2.1.14		15	A
Radio frequency susceptibility	1.2.3.3		20	U
Lightning induced transient susceptibility	1.2		22	C
Conducted susceptibility audio frequency	1.2.3.4.2		18	A
Induced signal susceptibility	1.2.3.4.3		19	Z
Emission of radio frequency energie	1.2.3.4.4		21	L

Electrical characteristics	
Temperature	Operating: -40°C to +70°C
	Survival: -55°C to +85°C
Supply	Min.: 17 V, Max.: 32.5 V
Leak voltage (target near)	1 VDC Max. under 25 mA
Output max current	25 mA resistive or inductive load
Maximum Capacitor load	22 nF
Electrical continuity	Between case and connector 20 mΩ Max.
Leakage current	500 µA Max. under 28 VDC
Current consumption	10 mA Max. under 32.5 VDC
Switching frequency	100 Hz Max.
Insulation resistance	100 MΩ Min. at 45 VDC
Dielectric strenght	> 500 VDC
Momentary power interruption	1 ms Max.
Power and reset	5 ms Max.
Protections	Against inversion of polarity
	Against permanent short circuit of the load
Weight	100 g Max.
Material case	Aluminium protected

Principles

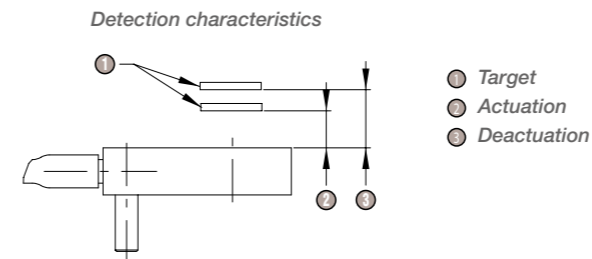

Temperature	-40°C to +70°C
Actuation distance	4 mm Min.
Deactuation distance	6 mm Max.

Connection

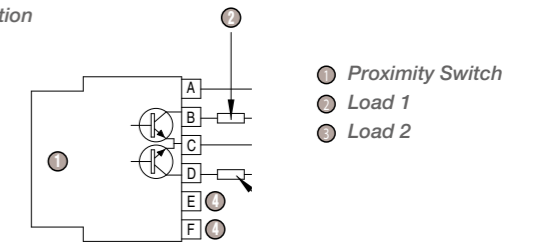

Situation	Output 1 Pin B	Output 2 Pin D
Target detected	High	Low
Target not detected	Low	High
Incorrect	Low	Low
Incorrect	High	High

Proximity switch must be connected with AWG24 minimum shielded twisted wires (EMI).

Dimensions (mm)

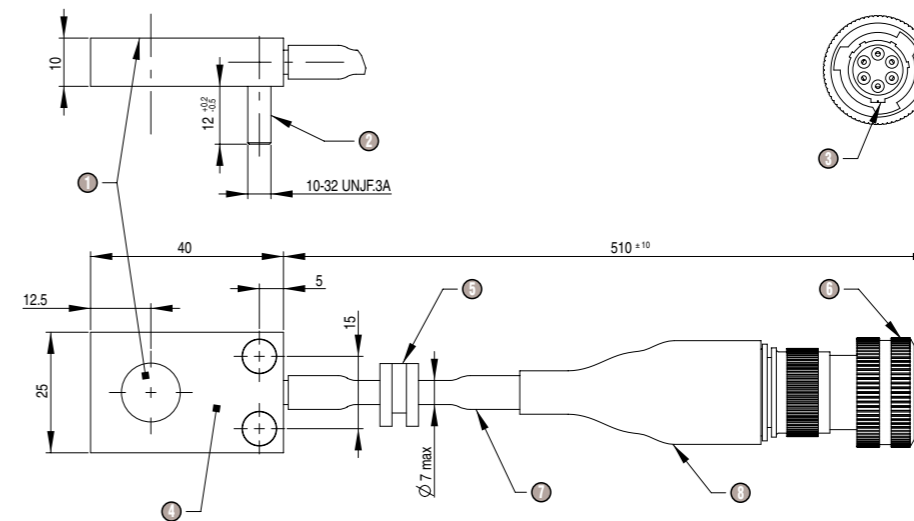

- ① Sensing face
- ② Nickel plated steel
- ③ Master key
- ④ Marking
- ⑤ Moveable grommet
- ⑥ Plug ASN-E0052010B6PN
- ⑦ Shielded cable
- ⑧ Protected boot

PROXIMITY SWITCH FOR LANDING GEAR FUNCTION



Specifications

Part numbers **DPI799238**

Mechanical characteristics

Weight	145 ±10 g
Housing	Stainless steel Front face: peek (Arlon 1000)

Electrical characteristics

Hysteresis ≤ 1.5 mm	for $D \leq 1.6$ mm: the detector will always be in detection mode
	for $D \geq 3.1$ mm: the detector will always be in non detection mode

Principles

Detection characteristics

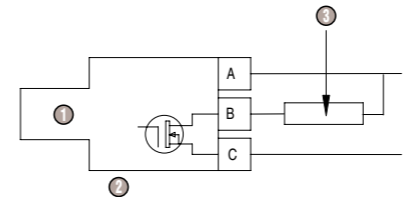

- ① Detector
- ② Output type: NPN
- ③ Load

Detection characteristics

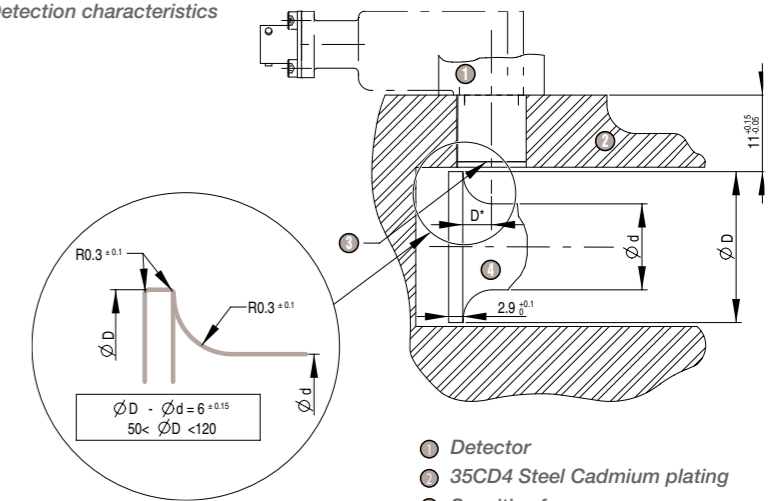

- ① Detector
- ② 35CD4 Steel Cadmium plating
- ③ Sensitive face
- ④ 35CD4 Cadmium plating

* Please refer to Electrical characteristics & Hysteresis P.76

Dimensions (mm)

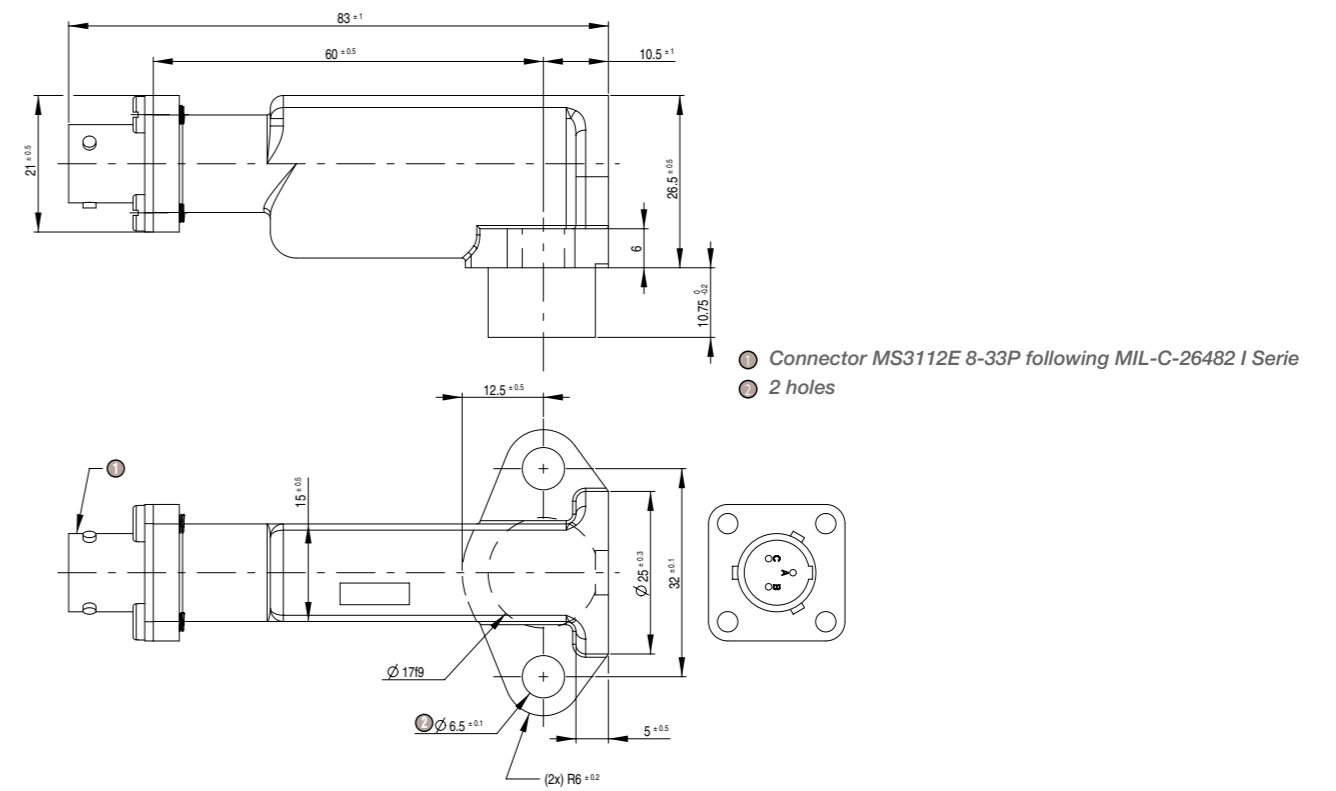

PROXIMITY SWITCH FOR THRUST REVERSER ACTUATOR FUNCTION

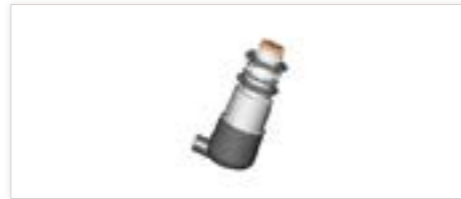

Specifications

Part numbers **DPI799079**

Environment characteristics

Condition	RTCA/DO-160D		
	Section	Category	
Temperature	4	F3	
Temperature variation	5	A	
Altitude	4	F3	
Humidity	6	B	
Waterproofness	10	R	
Salt spray	14.0	S	
Sand and Dust		N/A	
Vibration	8	H2 Curve D and P	
Operation shock and Crash safety	7.2/7.3	B	
Hermeticity	MILPRF8805E	watertight	
Supply voltage	16	A	
Voltage spike	17	A	
EMI	Conducted susceptibility	18	Z
	Induced signal susceptibility	19	Z
	Radio frequency susceptibility	20	Conducted W
	Emission of radio frequency energy	21	H
Explosion proof	9.0	E1	
Fluid susceptibility	11.0	F	
Fungus	13.0	F	
Magnetic effects		N/A	
Lighting indirect effect	22	Waveform Set A Level 4	
Icing	24	C	
Lighting direct effect		N/A	
Electrostatic discharge	25	15 kV	

Electrical characteristics

Temperature	Operating storage and survival: -55°C to +121°C	
Supply voltage	16 V Min., 32.5 V Max.	
Max. Consumption current	15 mA Max. under 32.5 V	
Output voltage	8 VDC Min., 32.5 VDC Max.	
Output leakage voltage (On)	1 V Max. under 50 mA	
Output leakage current (Off)	100 µA Max.	
Output current Max. 100 mA	Resistive or Inductive	
Maximum switching frequency	50 Hz	
Protections	Against inversion supply polarity and output polarity with load	
	Against permanent short circuit of the load	
Shock resistance	100 G/11 ms	
Dielectric test ISO 2678 Catégorie C	Dielectric strenght: 1 000 VAC - 1 Min. - 500 µA	
	Insulation resistance: 100 MΩ/500 VDC	
MTBF	= 115 000 flight hours	

Principles

Function: normally open

- when target is far , the output is not conductive
- when target is near , the output is conductive

Detection characteristics

- From -55 °C to +121 °C (-65 °F to +250 °F)
- Frontal approach
- Target: 15.87 mm (0.625 in) square; 1 mm (0.04 in) thickness material 15-5 PH
- Actuation distance 0.1 < Ad < 0.14 in or 2.5 < Ad < 3.55 mm
- Deactuation distance 0.145 < Dad < 0.18 in or 3.68 < Dad < 4.57 mm

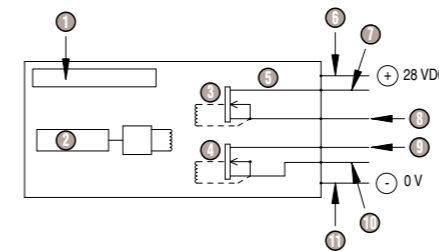

- ① Proximity switch
- ② Orange
- ③ Detection
- ④ Green
- ⑤ Out 1
- ⑥ Red
- ⑦ Out 2
- ⑧ Black
- ⑨ MOS N
- ⑩ Blue
- ⑪ White

Dimensions (mm)

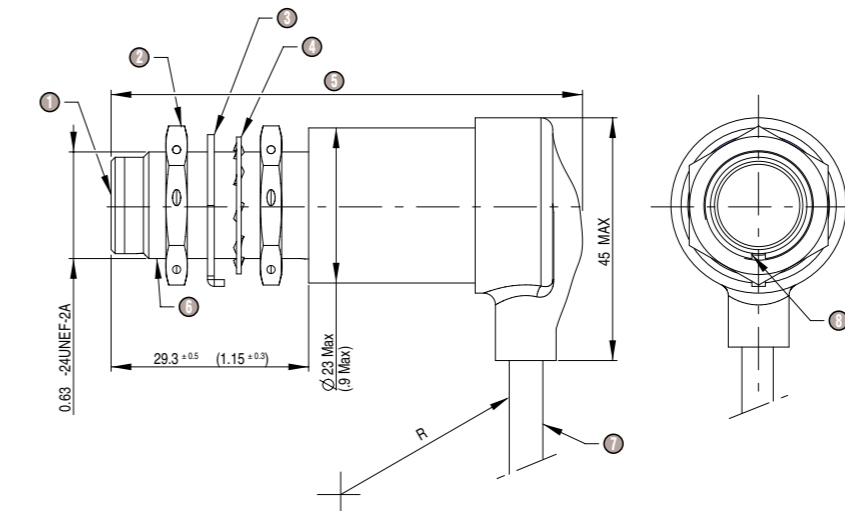

- ① Sensing face material flush and plastic
- ② Nut MS21340-05
- ③ Lock washer MS25081-C5
- ④ Lock washer MS35333-138
- ⑤ 80 Max. in the Proximity Switch axis
- ⑥ Keyway
- ⑦ Shielded cable
- ⑧ Keyway

AMERICAS**CANADA**

Tel.: +1 (855) 929-5465
americas.custserv@crouzet.com

MEXICO

Tel.: +1 (855) 929-5465
americas.custserv@crouzet.com

USA

+1 (855) 929-5465
americas.custserv@crouzet.com

EUROPE / MIDDLE EAST / AFRICA**BELGIUM**

Tel.: +32 (0) 2 620 06 05
Fax: +32 (0) 2 461 00 23
klantenservice@crouzet.com

FRANCE

Tel.: +33 (0) 475 802 101
Fax: +33 (0) 475 828 900
relationclient@crouzet.com

GERMANY / AUSTRIA

Tel.: +49 (0) 2103/9385930
Fax: +49 (0) 2103/980-222
kundenservice@crouzet.com

ITALY

Tel.: +39 (02) 38 594 099
Fax: +39 (02) 82 952 104
assistenzaclienti@crouzet.com

MOROCCO

Tel.: +212 5 20 48 03 40
sales.mena@crouzet.com

SPAIN / PORTUGAL

Tel.: +34 (91) 215 80 95
Fax: +34 (93) 2 20 02 05
atencionalcliente@crouzet.com

SWITZERLAND

Tel.: +41 (0) 225 67 57 90
Fax: +41 (0) 565 88 02 75
kundenservice@crouzet.com

THE NETHERLANDS

Tel.: +31 (0) 20-654 52 20
klantenservice@crouzet.com

UNITED KINGDOM

Tel.: +44 (0) 2076 600 025
customer.relation@crouzet.com

ASIA / PACIFIC**CHINA**

Tel.: +86 (752) 5303 200
china@crouzet.com

INDIA

Tel.: +91 (80) 6966 3600
india@crouzet.com

SOUTH KOREA

Tel.: +82 (2) 2679 8312
korea@crouzet.com

SOUTH ASIA PACIFIC

Tel.: +86 (752) 5303 200
eap@crouzet.com

Warning:

The product information contained in this catalogue is given purely as information and does not constitute a representation, warranty or any form of contractual commitment. Crouzet and its subsidiaries reserve the right to modify their products without notice. It is imperative that we should be consulted over any particular use or application of our products and it is the responsibility of the buyer to establish, particularly through all the appropriate tests, that the product is suitable for the use or application. Under no circumstances will our warranty apply, nor shall we be held responsible for any application (such as any modification, addition, deletion, use in conjunction with other electrical or electronic components, circuits or assemblies, or any other unsuitable material or substance) which has not been expressly agreed by us prior to the sale of our products.